

OPERATION MANUAL



THICKNESSER

Models

T-380, T-380S, T-20, T-20A, T-20S

Order Code W414, W414S, W415, W415A, W415S

EDITION No : TH-003
DATE OF ISSUE : 01/2024

MACHINE DETAILS

MACHINE	THICKNESSER
MODEL NO.	
SERIAL NO.	
DATE OF MANF.	

DISTRIBUTED BY





www.machineryhouse.com.au
www.machineryhouse.co.nz

NOTE:
 This manual is only for your reference. At the time of the compiling of this manual every effort to be exact with the instructions, specifications, drawings, and photographs of the machine was taken. Owing to the continuous improvement of the HAFCO METALMASTER machine, changes may be made at any time without obligation or notice. Please ensure the local voltage is the same as listed on the specification plate before operating any electric machine.

SAFETY SYMBOLS

The purpose of safety symbols is to attract your attention to possible hazardous conditions

 **WARNING** Indicates a potentially hazardous situation causing injury or death

 **CAUTION** Indicates an alert against unsafe practices.

Note: Used to alert the user to useful information



Fig.1

NOTE:
 In order to see the type and model of the machine, please see the specification plate. Usually found on the back of the machine. See example (Fig.1)

HAFCO METALMASTER

PRODUCT SPECIFICATIONS

Model: SB-375	Voltage: 240V/50Hz	
Capacity: 340L/m	Motor: 1200W	
Nett Weight: 105kg	FLC:5.6A	
MFG Date:		

Serial No:

Imported by www.machineryhouse.com.au Made in China
www.machineryhouse.co.nz

C O N T E N T S:

1. GENERAL MACHINE INFORMATION	
1.1. Specifications.....	4
1.2 Identification T-380.....	5
Identification T-20.....	6
Identification Drive Rollers & Cutter Head.....	7
2. IMPORTANT INFORMATION	
2.1 General Machinery Safety	8
2.2 Additional Safety For Thicknessers.....	11
2.3 Lifting Instructions.....	13
3. INSTALLATION	
3.1 Base Foundation and Securing Points.....	13
Placement Location.....	13
Levelling.....	13
3.2 Setting Up Attachments.....	15
Attaching the Support Rollers.....	15
Attaching the Handwheel.....	15
Attaching the Dust Hood.....	15
Dust Extraction.....	16
3.3 Connecting To The Power Supply.....	16
3.4 Test Run.....	17
4. OPERATION	
4.1. Basic Controls.....	17
Operation Overview.....	18
Operating Tips.....	19
Feed Rate.....	19
Depth of Cut.....	20
Bed Rollers Height.....	20
5. MAINTAINANCE	
5.1 Lubrication.....	21
Feed Roller Bushings.....	21
Table Height Worm Gear.....	21
Column and Leadscrews.....	21
Drive Sprockets and Chain.....	22
Table Height Sprockets and Chain.....	22
Gear Box Oil.....	22
5.2 Troubleshooting.....	23
6. ADJUSTMENTS	
6.1 Replacing Cutter Blades.....	25
6.2 Replacing Insert Type Cutters.....	26
6.2 Tensioning and Replacing Drive Belts.....	27
6.3 Adjusting Height Of In-feed Roller, Chlpbreaker, Pressure Bar & Out-feed Roller.....	28
6.4 Adjusting Kickback Fingers.....	29
6.5 Positioning The Chip Deflector.....	29
6.6 Setting Digital Readout.....	30
Spare Parts.....	31

1.1 SPECIFICATIONS

ORDER CODE	W414	W414S	W415	W415A	W415S
MODEL	T-380	T-380S	T-20	T-20A	T-20S
Material Width Capacity (mm)	380	380	508	508	508
Max. Stock Thickness (mm)	150	150	200	200	200
Minimum Material Length (mm)	175	175	190	190	190
Maximum Depth of Cut At Full Width (mm)	2	2	6	6	6
Cutter Type	HSS Blades - Straight	Carbide Inserts - Spiral	HSS Blades - Straight	HSS Blades - Straight	Carbide Inserts - Spira
Quantity of Cutters	3 x Blades	68 x Insert	4 x Blades	4 x Blades	92 x Inserts
Cutter Block Diameter (mm)	73	73	80	80	80
Cutter Block Speed (R.P.M)	5000	5000	5000	5000	5000
Quantity of Spirals	~	4	~	~	4
Length of Table (mm)	520	520	650	650	650
Length of Table with Extensions/Rollers (mm)	1015	1015	1470	1470	1470
Feed Speed (M/Min)	4.8 / 6	4.8 / 6	4.8 / 6	4.8 / 6	4.8 / 6
Dust Outlet Diameter (mm)	100	100	125	125	125
Motor Power (kW / HP)	1.5 / 2	2.2 / 3	3.75 / 5	2.25 / 3	3.75 / 5
Power Requirement	240V, 50Hz, 1Ph	240V, 50Hz, 1Ph	415V, 50Hz, 3Ph	240V, 50Hz, 1Ph	415V, 50Hz, 3Ph
Full-Load Current Rating (Amps)	12.5	14	8	18	8
Minimum Circuit Size (Amps)	15	15	10	20	10
Floor Space (W x D x H)	770 x 1015 x 1100	820 x 1015 x 1100	1000 x 1470 x 1030	1000 x 1470 x 1030	1000 x 1470 x 1030
Shipping Dimensions (L x W x H)	760 x 630 x 780	760 x 630 x 780	750 x 950 x 1100	750 x 950 x 1100	750 x 950 x 1100
Nett Weight (Kgs.)	230	230	420	420	420

1.2 IDENTIFICATION T-380

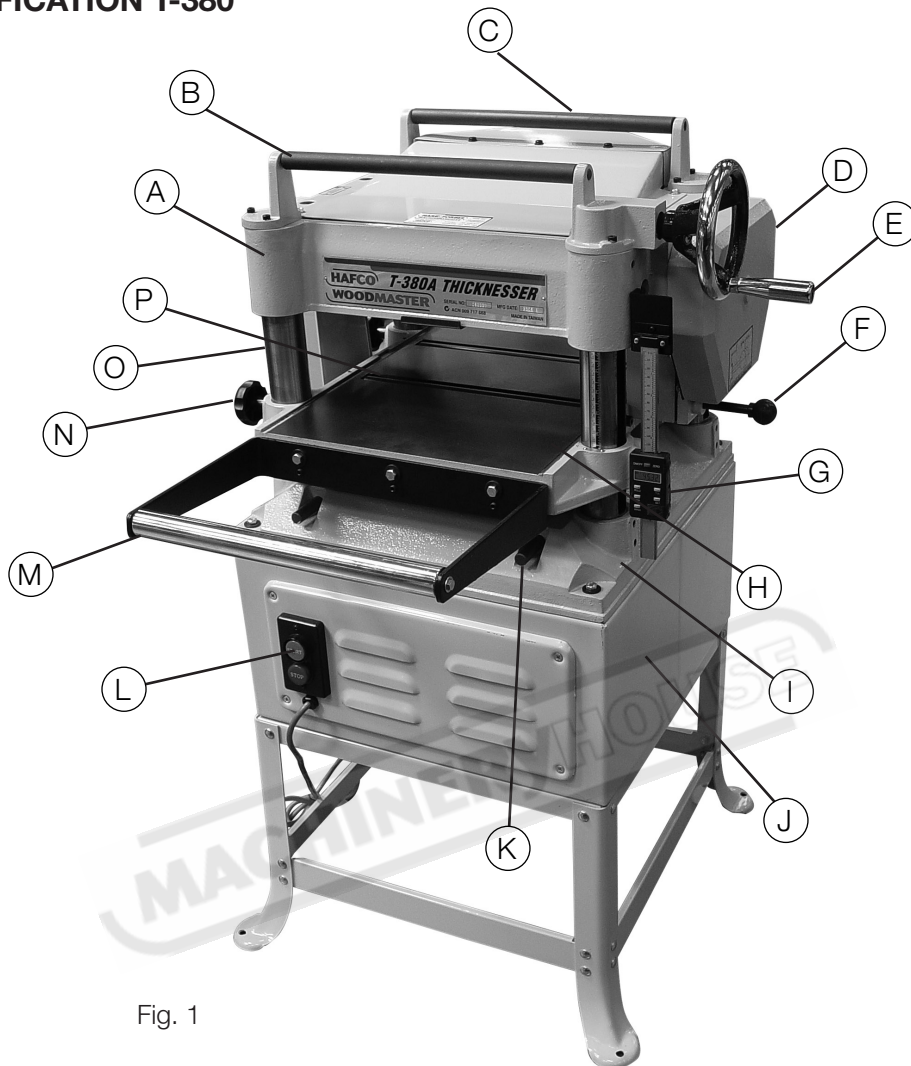

Fig. 1

A	Head Casting	I	Base
B	Return Rollers	J	Stand
C	Dust Chute	K	Lifting Handles
D	Gearbox Cover	L	ON/OFF Switch
E	Hand Wheel	M	Table Extension Roller
F	Gear Shift Handle	N	Locking Clamp
G	Digital Height Gauge	O	Column
H	Working Table	P	Table Rollers

1.2 IDENTIFICATION T-20 Series

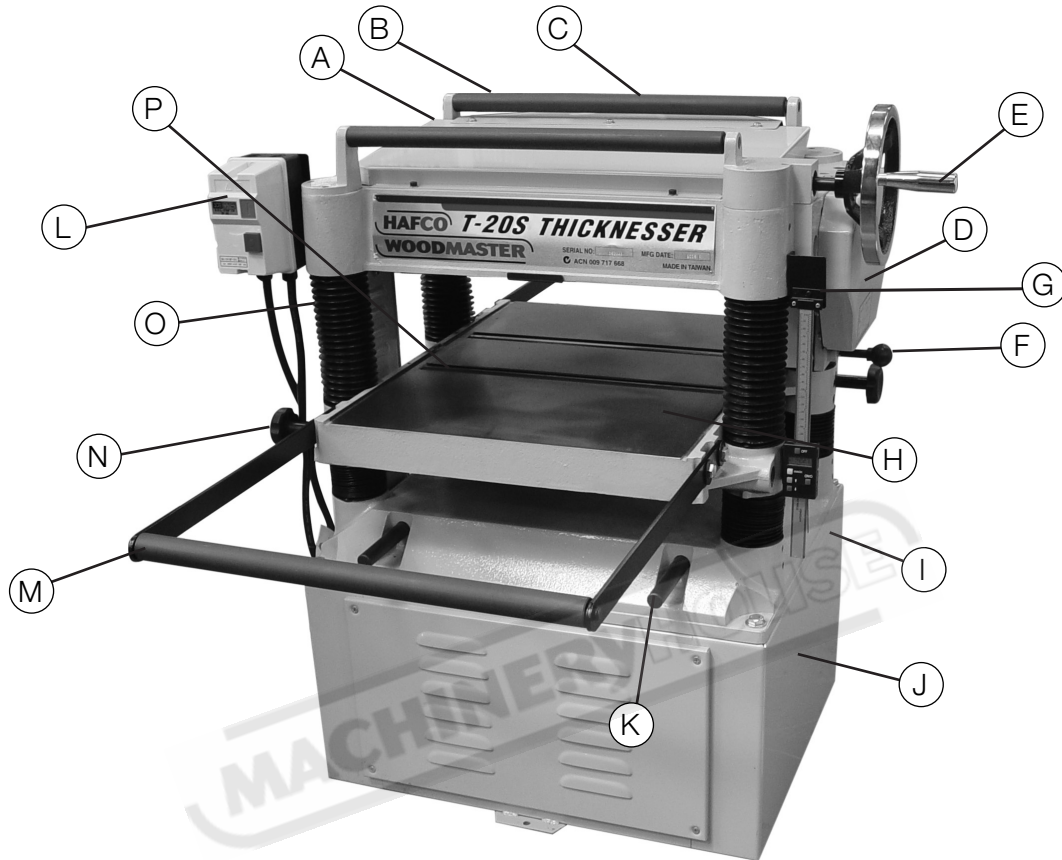
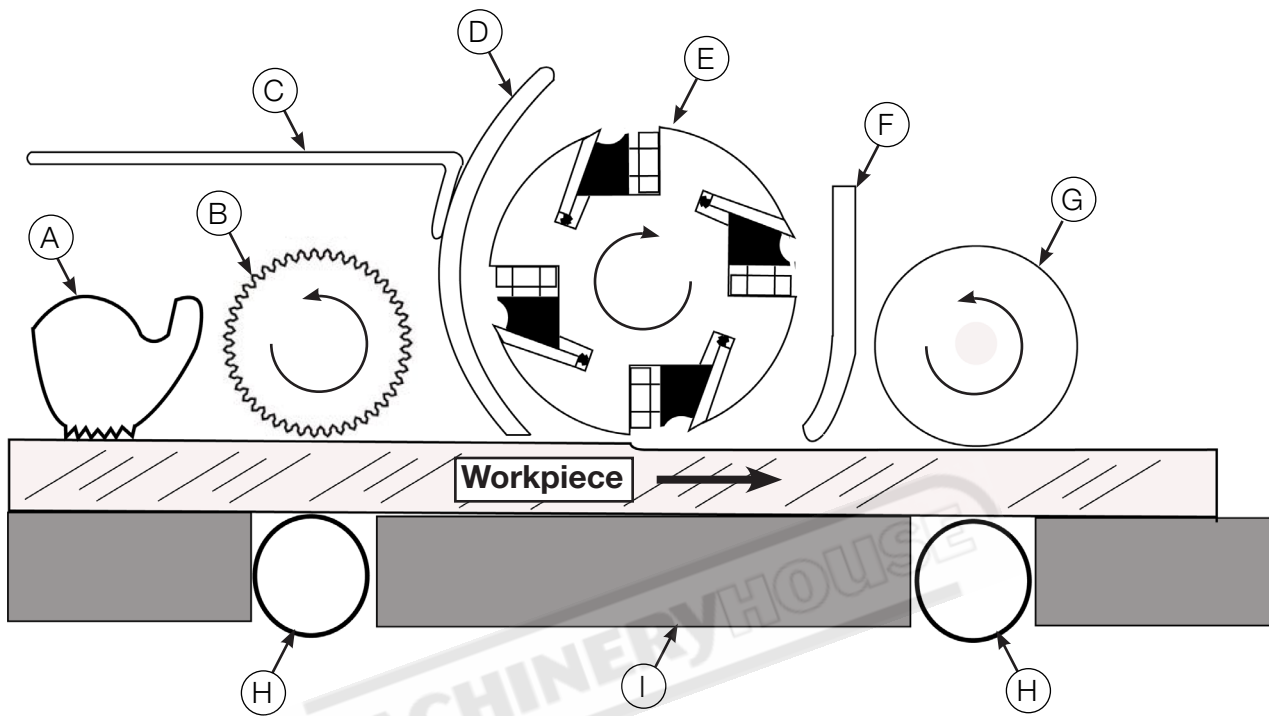

Fig. 2

A	Head Casting	I	Base
B	Return Rollers	J	Stand
C	Dust Chute	K	Lifting Handles
D	Gearbox Cover	L	ON/OFF Switch
E	Hand Wheel	M	Table Extension Roller
F	Gear Shift Handle	N	Locking Clamp
G	Digital Height Gauge	O	Column
H	Working Table	P	Table Rollers

1.2 IDENTIFICATION DRIVE ROLLERS AND CUTTER HEAD



- A.** Anti-Kickback Fingers: Provide additional safety for the operator.
- B.** Serrated Infeed Roller: Pulls the work piece toward the cutterhead.
- C.** Chip Breaker: Breaks off chips created by the cutterhead to prevent tearout and diverts the chips to the dust port.
- D.** Chip Deflector: Directs chips into the dust hood.
- E.** Cutterhead: Holds the cutter blades that remove material from the workpiece.
- F.** Pressure Bar: Stabilizes the workpiece as it leaves the cutterhead and assists in deflecting wood particles toward the dust hood
- G.** Outfeed Roller: Pulls the workpiece through the thicknesser.
- H.** Table Rollers: Provide a rolling surface to enable the feed rollers to pull the work piece along.
- I.** Table: Provides a smooth and level path for the workpiece as it moves through the thicknesser.

2. IMPORTANT INFORMATION

2.1 GENERAL MACHINE SAFETY

INSTRUCTION MANUAL.

Read and understand this instruction manual BEFORE using the machine. Store the manual in a safe place for future reference.

ENVIRONMENTS.

Do not use any machinery in areas that are cluttered, wet, or has poor lighting. Operating machinery in these areas greatly increases the risk of accidents and injury.

TRAINED OPERATORS.

A higher risk of being hurt or killed can occur with untrained operators.

Only trained or supervised people should use the machine. Disconnect the power, or remove the switch keys, to prevent the machine's unauthorized use, when the machine is not being used.

Children must not operate this machine.

ALERTNESS.

Never operate under the influence of drugs or alcohol, when tired, or when distracted. Mental alertness is required for the safe operation of machinery.

ELECTRICAL INJURY RISKS.

Operators can be shocked, burned, or killed by touching live electrical components or improperly grounded machinery. To reduce this risk, only allow a qualified electrician or service personnel to do electrical installation or repair work, and always disconnect power before accessing or exposing electrical equipment.

DISCONNECT POWER .

Always disconnect the machine from the power supply BEFORE making adjustments, changing tooling, or servicing the machine. This prevents an injury risk from unintended startup or contact with live electrical components.

EYE PROTECTION.

Always wear AS/NZ-1336 approved safety glasses or a face shield when operating or observing machinery to reduce the risk of eye injury or blindness from flying particles.

Everyday eyeglasses are NOT approved safety glasses.

HEARING PROTECTION.

Extended exposure to this noise without hearing protection can cause permanent hearing loss. Always wear hearing protection when operating or observing loud machinery.



WARNING

Keep hands and fingers away from the cutter. Stop the cutter before opening the hand protection shield. Moving blade cutter hazard may cause serious injury.

2.1 GENERAL MACHINE SAFETY

PROPER CLOTHING.

Do not wear clothing, or jewellery that can become entangled in moving parts. Always tie back or cover long hair. Wear non-slip footwear to reduce the risk of slipping and losing control which could cause accidentally contact with the cutting tool or moving parts.

HAZARDOUS DUST.

Some dust created by machinery operations may be hazardous to your long-term health. Always wear a safety approved respirator to reduce the risk to your health. Be aware of dust hazards associated with each workpiece material.

CHILDREN & BYSTANDERS.

Children and bystanders must be kept at a safe distance from the work area. Stop using the machine if they become a distraction.

OPERATING POSITIONS.

Avoid awkward hand positions that make the workpiece control difficult or increase the risk of accidental injury. Keep proper footing and balance at all times when operating the machine.

KEEPING THE WORK AREA CLEAR.

Never leave chuck keys, wrenches, or any other tools on the machine. Always verify that the work area is clear before starting! Tools left on machinery can become dangerous projectiles upon startup.

GUARDS & COVERS.

Guards and covers reduce accidental contact with moving parts or flying debris. Make sure they are properly installed, undamaged, and working correctly BEFORE operating the machine.

USING THE CORRECT TOOL.

Only use the tool for its intended purpose. Do not force the tool or an attachment to do a job for which it was not designed. Never make unapproved modifications. Modifying the tool or using it for a purpose that it was not intended for may result in malfunction or mechanical failure that can lead to personal injury or death!

FORCING MACHINERY.

Do not force the machine. It will do the job safer and better at the rate for which it was designed.

NEVER STAND ON THE MACHINE.

Serious injury may occur if the cutting tool is contacted or the machine is tipped.

2.1 GENERAL MACHINE SAFETY

MAKING THE MACHINE STABLE.

Before starting, verify the machine is stable and the mobile base (if used) is locked. Unexpected movement during operation greatly increases risk of injury or loss of control.

USE RECOMMENDED ACCESSORIES.

Check with the distributor or the manufacturer for recommended accessories. Using improper accessories could increase the risk of serious injury.

UNATTENDED OPERATION.

Turn the machine OFF and ensure all moving parts are completely stopped before walking away. This will reduce the risk of accidental injury. Never leave the machine running while unattended.

MAINTAINENCE.

Follow all the lubrication schedules and maintenance instructions to keep the machine in good working condition. A machine that is improperly maintained could malfunction, and cause serious personal injury or death.

DAMAGED PARTS.

Regularly inspect the machine for damaged, loose, or misaligned parts. Check for any condition that could affect the safe operation. Immediately repair or replace BEFORE operating the machine. For your own safety, DO NOT operate the machine with damaged parts!

MAINTAIN POWER CORDS.

When removing the cords connected to the machine from the power supply, grab and pull the plug—NOT the cord. Pulling the cord may damage the wires inside. Do not handle the cord or plug with wet hands. Avoid cord damage by keeping it away from heated surfaces, high traffic areas, and wet or damp locations.

EXPERIENCING DIFFICULTIES.

If at any time you are experiencing difficulties performing the intended operation, stop using the machine, and contact your local distributor for technical support

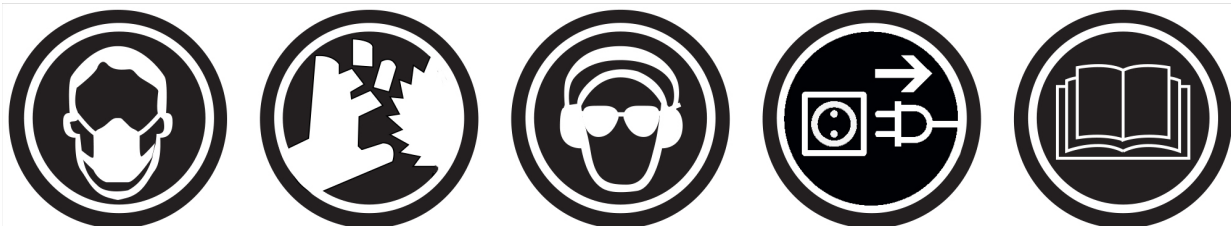

2.2 ADDITIONAL SAFETY FOR PLANER/THICKNESSERS

DO NOT use this machine unless you have been instructed in its safe use and operation and have read the instruction manual.



Safety glasses must be worn at all times in work areas.



Long and loose hair must be contained.



Appropriate footwear with substantial uppers must be worn.



Close fitting/protective clothing must be worn.



Rings and jewellery must not be worn.



Hearing protection must be worn when using this machine.

PRE-OPERATIONAL SAFETY CHECKS

1. Check workspaces are clear and no slip/trip-hazards are present.
2. Check safety guards are adjusted and operate to give maximum protection.
3. Where a bridge guard is fitted adjust the guard to ensure a maximum of 2mm clearance between guard and the timber.
4. Do not plane stock with structural defects.
5. Locate and ensure you are familiar with the operation of the ON/OFF starter and E-Stop (if fitted).
6. Set depth of cut and lock table. Never make a single cut greater than 2mm.
7. Check and lock fence in position.
8. Start the dust extraction unit before using the machine.

OPERATIONAL SAFETY CHECKS

1. Hands must not be closer than 100mm from the cutter head when it is rotating.
2. Use push blocks wherever possible.
3. Never leave the machine while it is running.
4. Place cupped boards with the concave side against the table.
5. Plane with the grain. Hold the workpiece firmly and apply even feed rate.
6. Operator should stand to side of infeed table to avoid possible kickbacks.
7. Before making any adjustments switch off and wait for the cutter head to completely stop.

HOUSEKEEPING

1. Switch off and reset all guards to a fully closed position after use.
2. Reset the depth of cut to zero after use.
3. Leave the machine in a safe, clean and tidy state.

DON'T

- Do not surface stock less than 300mm long x 20mm wide x 15mm thick
- Rebating at the end of the cutter-block
- Planing end grain

2.2 ADDITIONAL SAFETY FOR THICKNESSERS

INFEEED AND OUTFEED ROLLER CLEARANCE.

The infeed and outfeed rollers are designed to feed material into and away from the spinning cutterhead, and doing so clamps the material firmly to the base. To avoid serious personal injury, always keep hands, clothing, jewellery, and long hair away from the infeed and outfeed rollers during operation.

DISCONNECT BEFORE ADJUSTMENTS.

To avoid unexpected start-up and serious personal injury, always disconnect the thicknesser from the power before performing adjustments, maintenance, or service.

PINCH POINTS

Beware of pinch points that can cause serious damage to fingers and hands especially around the support rollers on the out feed. (Fig.2.1) It is best practice to wait for the work-piece to stop feeding before removing.

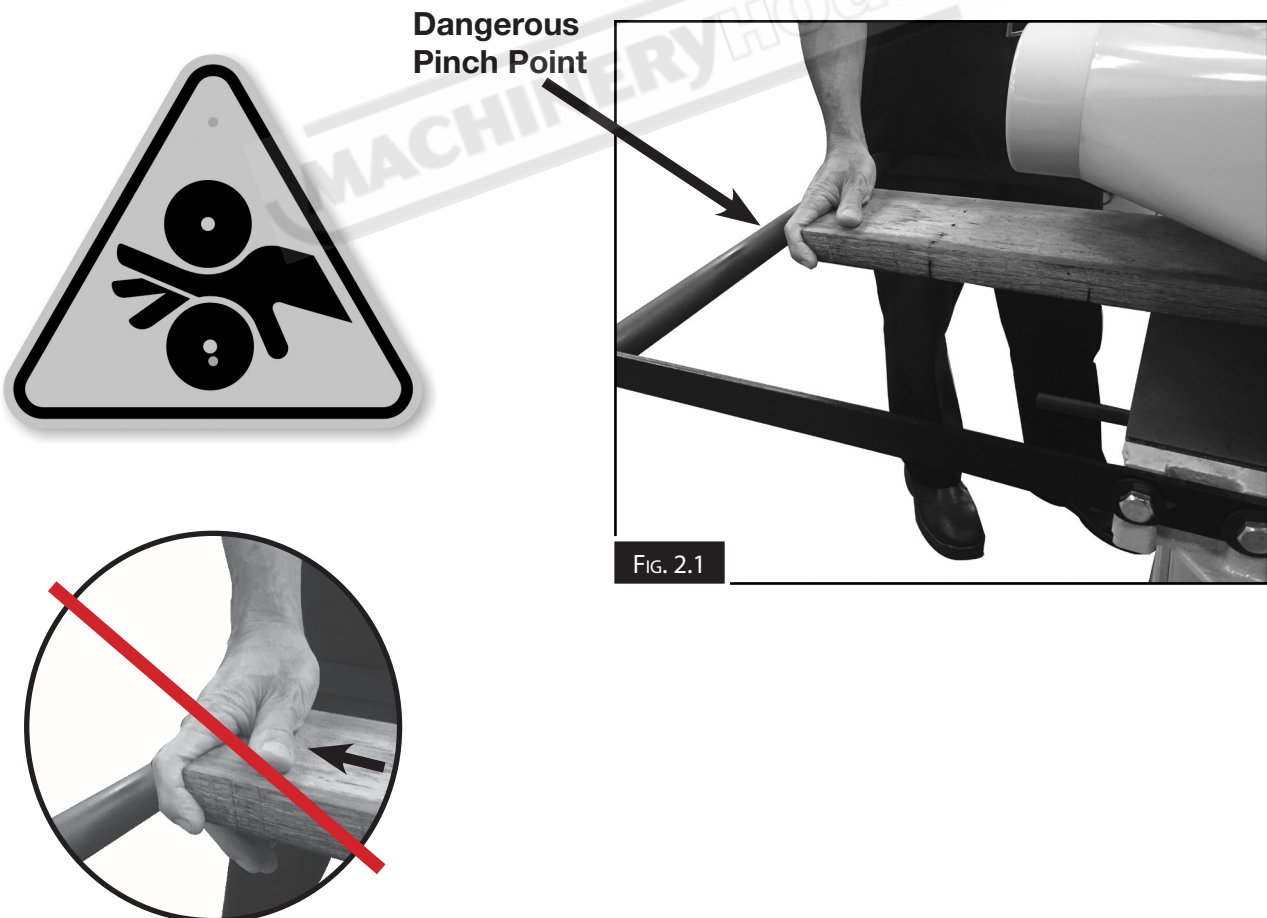

2.3 LIFTING INSTRUCTIONS

The thicknessers in this manual are heavy. Serious personal injury could occur if safe moving methods are not used.

Get assistance and use the correct lifting equipment to move the shipping crate and when removing the machine from the crate.

NOTE: Check the weight of the machine on the specification plate before lifting the machine and only use approved lifting slings.

LIFTING

The cabinet stand on your thicknesser is equipped with four lifting bars that pull out in order to lift the machine. Once the machine is in place the handles can be pushed back into the casing. Make sure that machine is kept in a level position while lifting, (Fig. 2.2)

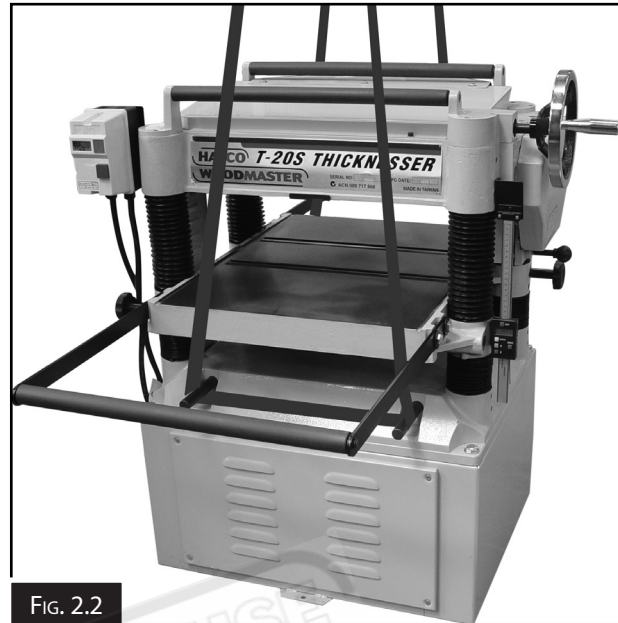

FIG. 2.2

3. INSTALLATION

3.1 BASE FOUNDATION AND LEVELLING

Check the weight and footprint specifications of your machine. Some residential floors may require additional reinforcement to support both the machine and operator. Hafco recommends that for best results the machine should be placed on a cement reinforced floor with a minimum thickness of 150mm.

PLACEMENT LOCATION

Consider the existing and all anticipated needs, the size of the material to be processed through the machine, and extra space for auxiliary stands, work tables or other machinery when picking a location for the machine. See Fig. 3.1 on Page 14 for the minimum working clearances.

LEVELLING

With the machine in position, test the table surface lengthwise and crosswise with machinist level. Place metal shims under the low corners until the machine is level. Check that all four corners are supported, and the machine does not rock, then tighten the hold down bolts, retest the level of the table surface in both directions; and adjust again if necessary.

3.1 BASE FOUNDATION AND LEVELING Cont.

Model T-380

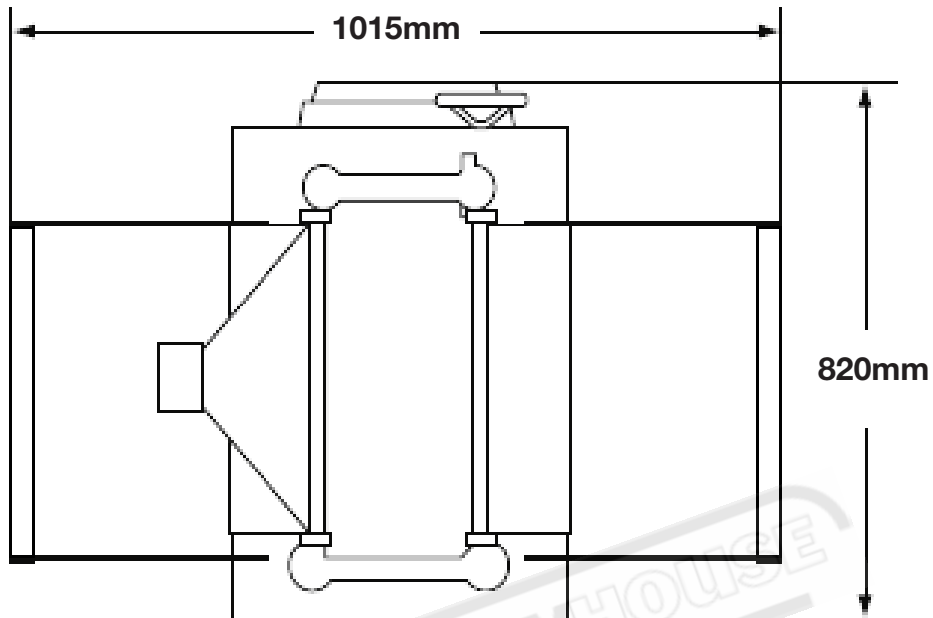

Model T-20

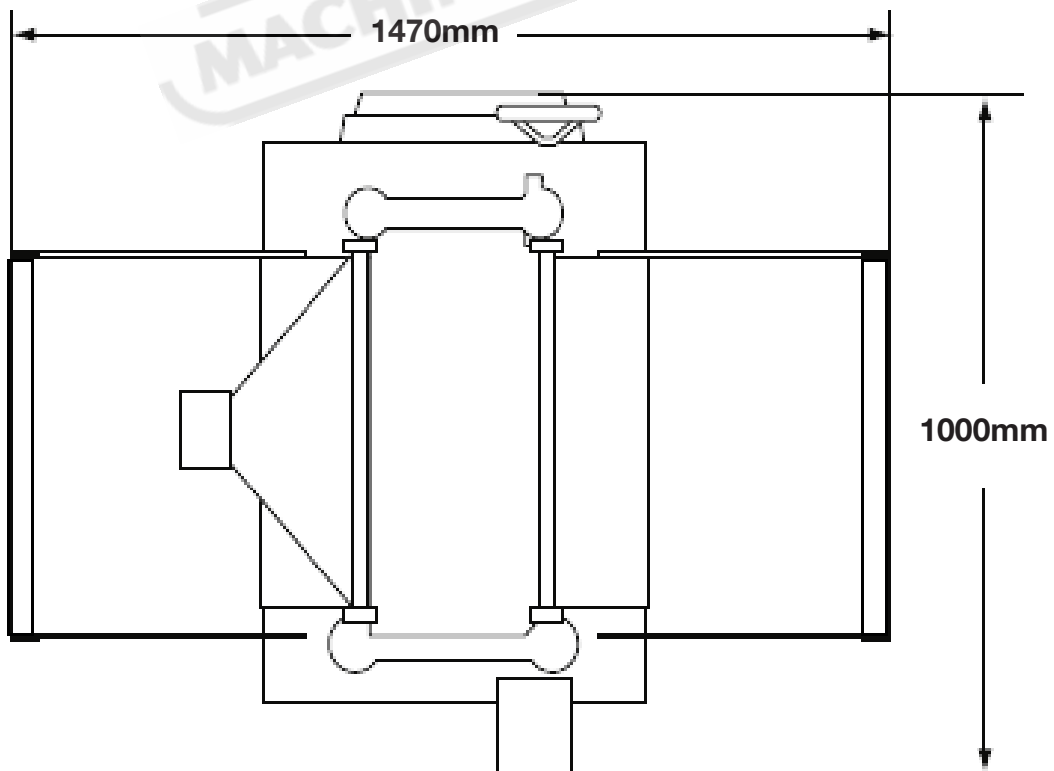

FIG. 3.1

3.2 SETTING UP ATTACHMENTS

ATTACH THE SUPPORT ROLLERS

Attach the table extension rollers to the thicknesser table with the hex bolts, lock washers, and flat washers, but do not fully tighten the bolts at this time.

Using a straightedge as a guide, position the support rollers evenly with the table, then fully tighten the hex bolts. (Fig. 3.2)

Note: Do not rest the straightedge on the table rollers which would give you a false reading.



FIG. 3.2

ATTACH THE HAND WHEEL

Place the bushing on the hand wheel shaft and insert the key into the shaft keyway. Slide the hand wheel on the shaft and secure it with the hex nut and flat washer, as shown in Figure 3.3



FIG. 3.3

ATTACH THE DUST HOOD

Attach the dust hood to the top of the thicknesser with the 3 hex bolts, flat washers, and hex nuts as shown in Figure 3.4, then attach the bottom of the dust hood to the thicknesser with the cap screws.

Note: You will need to reach into the dust hood to hold the hex nuts while tightening the hex bolts.

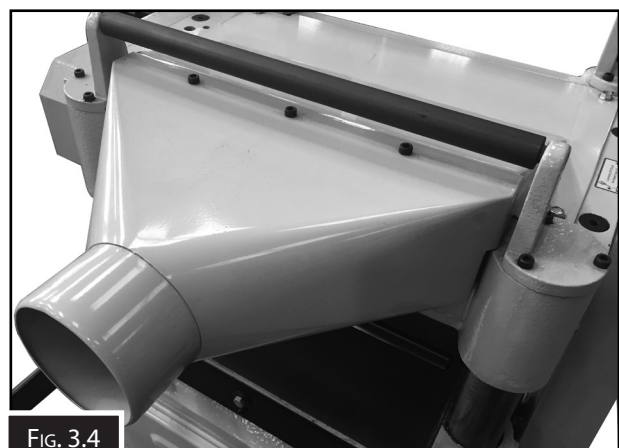

FIG. 3.4

DUST EXTRACTION

DO NOT operate these thicknessers without an adequate dust collection system. This thicknesser creates substantial amounts of wood dust while operating. Failure to use a dust collection system could result in short and long-term respiratory illness. HAFCO recommends that a Dust Extractor with a minimum of 680 C.F.M.

Fit the hose to the dust hood and clamp. (Fig.3.5)

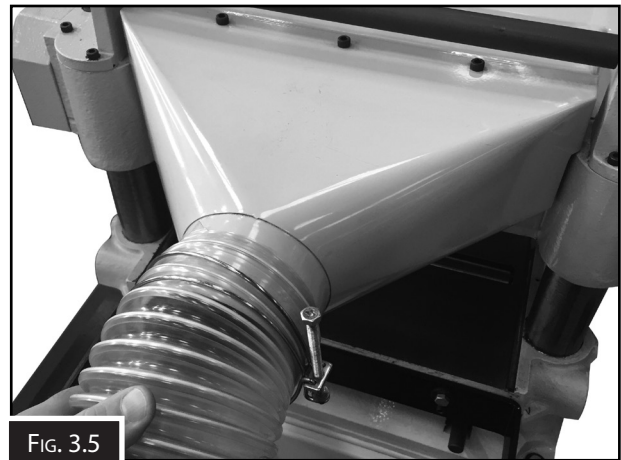

FIG. 3.5

3.3 CONNECTING TO THE POWER SUPPLY:

The electric motor, switch, and cord are supplied with the Thicknessers. If a plug is fitted, the plug must be plugged into a matching outlet that is properly installed and grounded in accordance with the local electrical codes. The power cord must have an earth pin.

You **MUST** connect your machine to a grounded circuit that is rated for the amperage given below. Never replace a circuit breaker on an existing circuit with one of higher amperage without consulting a qualified electrician. Never replace a plug with a plug of lower amperage.

Model	T-380A	T-380S	T-20	T-20	T-20S
POWER REQUIRED	240V 50 Hz	240V 50 Hz	415V 50 Hz	240V 50 Hz	415V 50 Hz
AMPS REQUIRED	15	15	15	20	15
FULL LOAD CURRENT	12.5	14	8	18	8

⚠ WARNING

Improper connection of the motor can result in a risk of electrical shock.

If it is necessary to use an extension lead, the lead should be grounded and be able to carry the correct amperage. Use a short lead length, to avoid power loss and over-heating.

All electrical work must be carried out by a qualified electrician.

IMPORTANT: *An extension lead should only be used as an interim solution until the machine can be plugged directly into the socket. For best protection, if possible use a surge-protected plug outlet.*

NOTE:

*Electrocution or fire could result if the machine is not grounded and installed in compliance with electrical codes. Compliance **MUST** be verified by a qualified electrician!.*

3.4 TEST RUN

Before starting the test run it is important that you make sure there is oil in the gearbox before proceeding. To check the oil, remove the gearbox cover, then remove the gearbox fill plug. (Fig. 3.6)

Using the short end of a clean hex key, dip it inside the fill hole and then remove it.

If the end of the hex wrench is coated with oil, then the gearbox oil level is okay. Replace the fill plug. If the end of the hex key is not coated with oil, then oil needs to be added. Refer to the gearbox filling instructions on Page 22

Once the oil level has been checked, test run your machine to make sure it runs properly and is ready for operation. Before you start the machine make sure you understand the safety instructions in the manual and that the machine has been set up correctly.

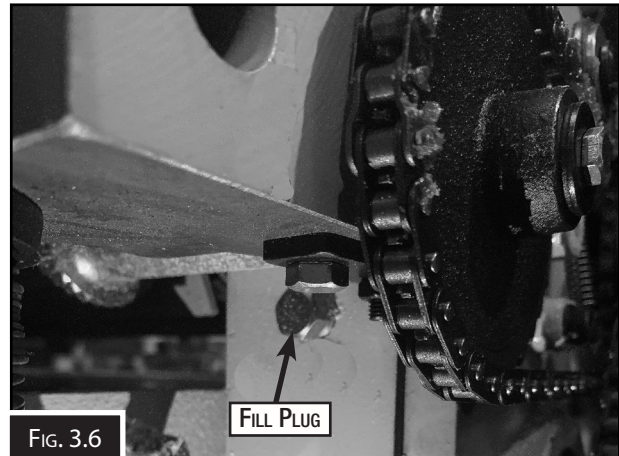

FIG. 3.6

FILL PLUG

NOTE: Make sure all tools and objects used during the setup have been cleared away from the machine.

Start the machine and verify that [1] The motor powers up and runs correctly and [2] the safety stop button safety works correctly.

If, during the test run, there is an unusual noise or vibration, stop using the machine straight away and locate the source of the noise or vibration.

If unsuccessful consult the Troubleshooting section on Page 23.

4. OPERATION

4.1 BASIC CONTROLS.

The following descriptions will help you to become familiar with the basic controls of your machine. (Refer Fig. 4.1 on page 18)

- A. Magnetic ON/OFF Switch:** Starts/stops the Thicknesser.
- B. Return Rollers:** Provide a convenient method for returning the workpiece to the infeed side of the Thicknesser.
- C. Table Height Handwheel:** Controls the elevation of the table under the cutterhead.
- D. Feed Rate Control Knob:** Switches the feed rollers between high and low feed rates or, in the center position, stops the feed rollers.
- E. Table Locks:** Locks the table in position so it does not move during operations.
- F. Digital Height Gauge:** Displays the height movements and position.

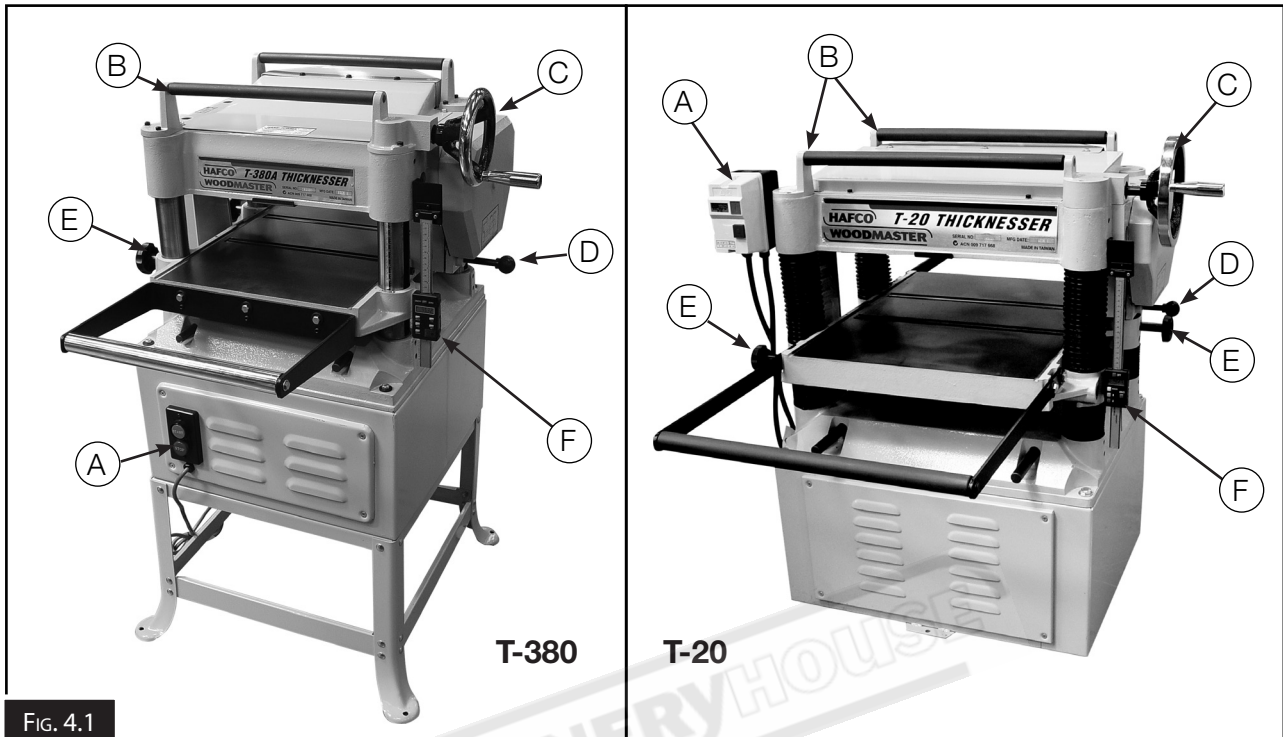

FIG. 4.1

OPERATION OVERVIEW

This section gives you the basic process that happens during an operation with this machine. Familiarize yourself with this process to better understand the remaining parts of the Operation section.

To complete a typical operation, the operator should do the following:

1. First check that the workpiece is clean and free of any defects or foreign materials that might cause kickback or damage the cutters.
2. Adjusts the height of the table for the correct depth of cut.
3. Start the dust collection system.
4. Connect the thicknesser to the power supply and turn the machine ON.
5. Move the Feed Rate Control Lever (Fig. 4.1) to the correct position
6. The operator should place their body to the side of the machine, then lay the workpiece on the infeed table and feed it into the machine until the infeed roller engages it and moves it past the cutterhead.
7. When the workpiece exits the thicknesser, return it to the infeed table, using the return rollers and make as many passes as necessary.
8. When finished turn the machine OFF.

OPERATING TIPS

- ❑ Wherever possible use the full width of the thicknesser cutters. If the width is smaller than the width of the cutters, alternate the cutting path between the left, the right and the middle of the table to evenly distribute the wear across the cutters.
- ❑ Scrape all glue off joined boards before putting the timber through the thicknesser.
- ❑ ONLY machine natural wood. Do not machine wood composites or any other man-made material.
- ❑ Machine the workpiece with the grain. NEVER feed end-cut or end-grained lumber into your machine.
- ❑ Keep the work area clear.
- ❑ Always true up any cupped or warped stock on a jointer or bandsaw before placing it through the thicknesser.
- ❑ When making multiple passes through the thicknesser with long stock, use the stock return rollers on top of the machine to move the material back to the infeed side.
- ❑ When possible, machine both faces of the workpiece so that they will be parallel with one another.

FEED RATE

The infeed and outfeed rollers move the workpiece through the thicknesser while keeping it flat and providing a consistent rate of movement.

Use the two feed rates as stated below:

- Low Feed Rate.....Roughing Pass
- High Feed Rate.....Finishing Pass

The three different positions of the feed rate control knob are as follows.:

- Push the knob in to use the high feed rate
 - T-380 20 fpm
 - T-20 20 fpm
- Pull the knob out to use the low feed rate
 - T-380 16 fpm
 - T-20 16 fpm
- Move the knob to the center position to place the gearbox in neutral.

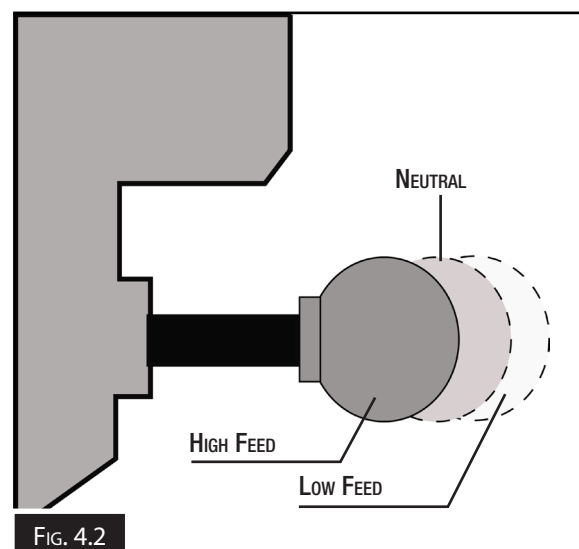

FIG. 4.2

DEPTH OF CUT

The depth of cut on the thicknesser is controlled by using the handwheel on the right side of the machine. Rotating the handwheel clockwise raises the table.

The depth of cut can be read directly from the inch/millimeter scale on the R/H side column of the machine and from the digital display.

One turn of the handwheel raises or lowers the table approximately 1.6mm. The thicknesser can machine material with a thickness of 6-150mm (T-380) 6-200mm (T-20). The correct depth of cut varies according to wood hardness and the workpiece width. HAFCO recommends a maximum depth of cut of no more than 1.6mm each pass.

Light cuts will give a better result and put less stress on the planer.

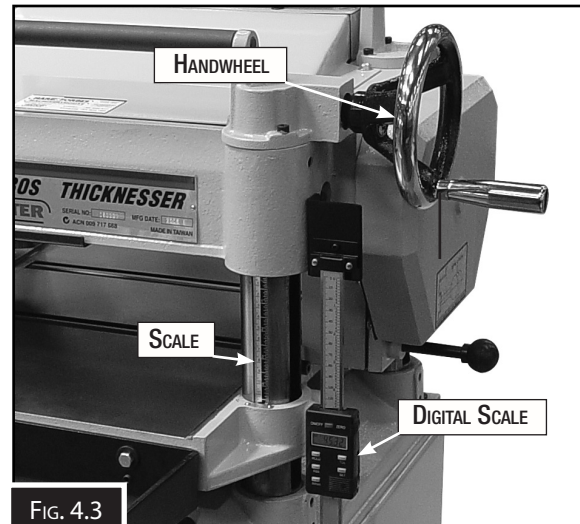

FIG. 4.3

BED ROLLER HEIGHT

The table rollers are set to the height for general machining when the machine leaves the factory and most operators will not need to adjust them on their machines. However, the height of the table rollers may vary, for different types of material being machined. The normal range for the table roller height is 0.05–0.5mm above the table surface. (Fig. 4.4)

When machining rough timber, set the rollers high to keep the timber from dragging across the table. When machining milled timber, set the rollers low.

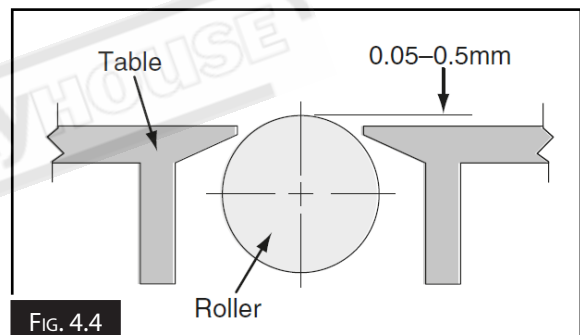

FIG. 4.4

To adjust the table rollers:

1. DISCONNECT MACHINE FROM POWER!
2. Lower the table to the bottom position
3. Loosen the set screws above each of the four roller adjustment hex bolts, two on each side (Fig. 4.5).
4. Using a straight edge and feeler gauge, rotate the eccentric adjustment hex bolts to raise or lower the bed rollers until they are the desired height above the table surface.
5. Verify that both sides of each roller are at the same height, then re-tighten the four set screws to secure the setting.

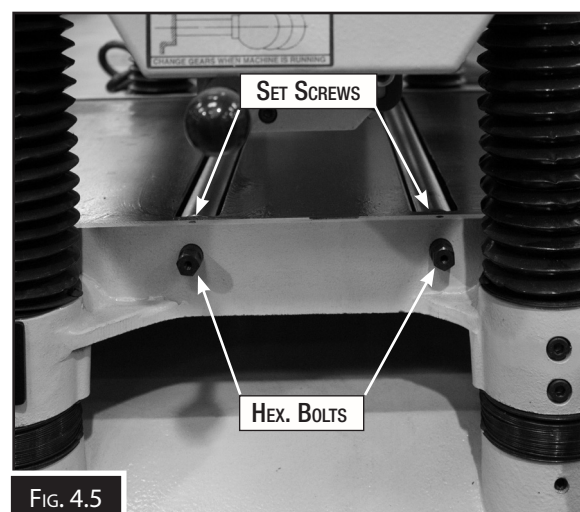

FIG. 4.5

5. MAINTENANCE

5.1 LUBRICATION

The thickener is supplied with bearings that are lubricated and sealed at the factory. These bearing do not require any further attention unless they need to be replaced. If a bearing fails, the thickener will probably develop a noticeable rumble or vibration, which will increase when the machine is under load. The bearings are standard sizes and can be replaced.

FEED ROLLER BUSHINGS

The infeed and outfeed rollers rotate inside bushing blocks on both ends of the rollers. Add 2–3 drops of SAE 30W oil to the center hole of the four feed roller tension adjustment bolts on top of the head casting. (Fig. 5.1)

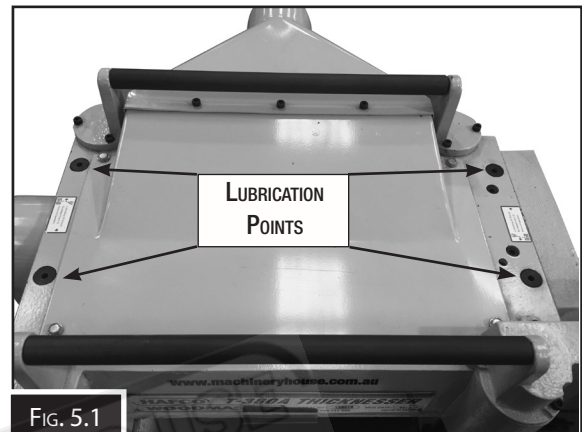

FIG. 5.1

TABLE HEIGHT WORM GEAR

Remove the three cap screws that secure the worm gear housing (see Fig. 5.2), then lift the housing and handwheel assembly off the machine. Clean away any debris from the housing and gears, then brush on a moderate amount of multi-purpose grease to the gear teeth.

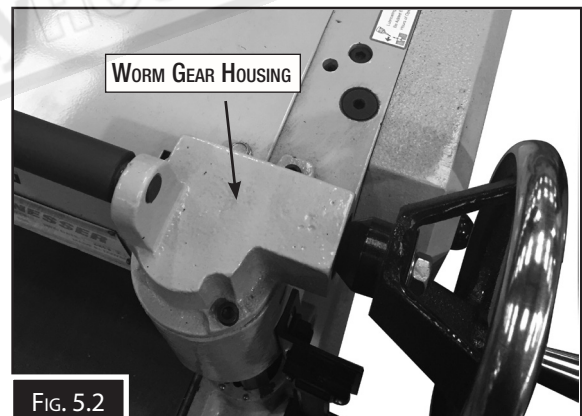

FIG. 5.2

COLUMNS AND LEADSCREWS (T-380)

The table is supported and moves on the columns by the rotation of the leadscrews inside the columns. (Fig. 5.3)

Apply a thin coat of SAE 30W oil to the outside surface of the columns and brush on a light application of multi-purpose grease to the leadscrew threads. Move the table up and down to distribute the lubricant.

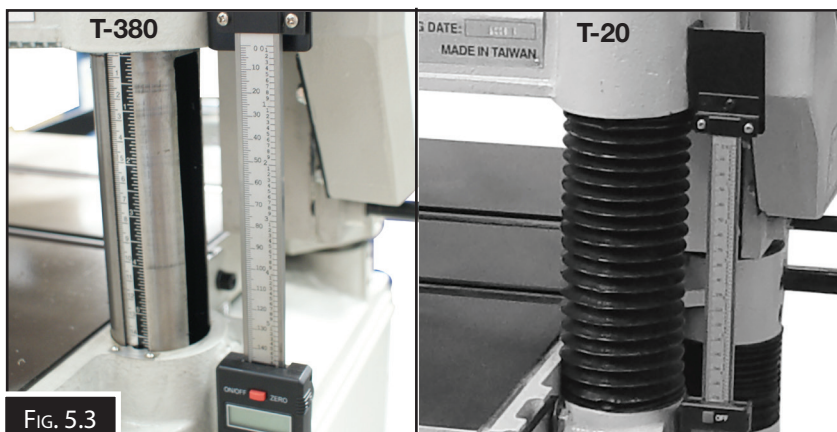

FIG. 5.3

T-20 COLUMNS & LEADSCREWS

Slide the cover up and apply a thin coat of SAE 30W oil to the outside surface of the columns and brush on a light application of multi-purpose grease to the leadscrew threads. Move the table up and down to distribute the lubricant.

Move the cover down to protect the machine surfaces.

DRIVE SPROCKETS AND CHAIN

The infeed and outfeed rollers are powered through the drive chain from the cutterhead on the right hand side of the machine. (Fig. 5.4) Remove the table height handwheel and the safety covers attached to the outside of the drive chain cover, then remove the cover to access these parts.

Use a clean rag to wipe away any debris and grime, then brush on a light coat of SAE 30W oil to the chain and sprockets.

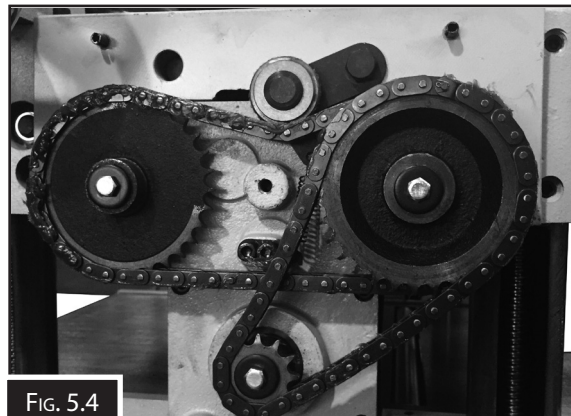

FIG. 5.4

TABLE HEIGHT SPROCKETS AND CHAIN.

The column leadscrews, responsible for the table lift, are synchronized by a chain and sprockets setup located underneath the base of the thickener.(Fig. 5.5) To access these parts, remove the front and rear cabinet panels. Use a clean rag to wipe away any debris and grime, then brush on a light coating of SAE 30W oil to the chain and sprockets.

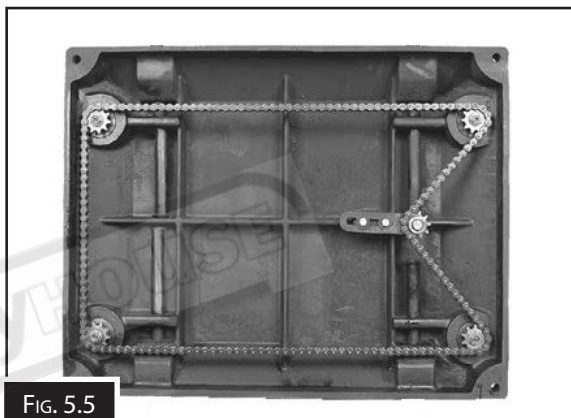

FIG. 5.5

GEARBOX OIL

The gearbox oil should be changed after the first 20 hours of operation to clear away any debris inside the gearbox, then changed yearly there after. To fill the gearbox oil, remove the drive chain cover. Once removed the drain and the fill plugs will be able to be accessed.

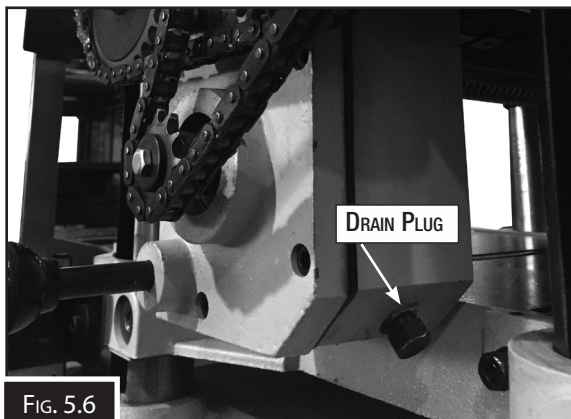

FIG. 5.6

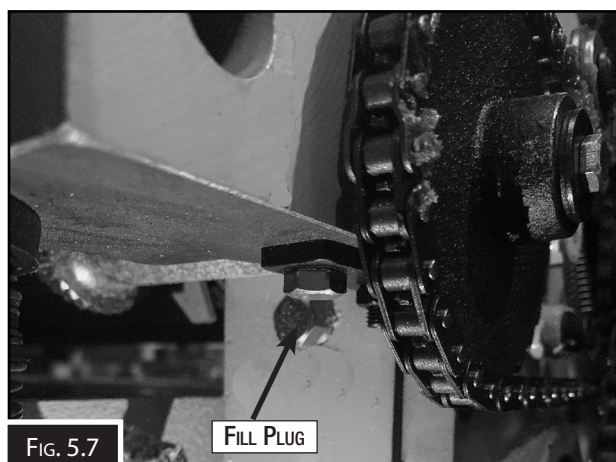

FIG. 5.7

Drain the oil from the gearbox by removing the drain plug (Fig.5.6)
 Replace the gearbox oil with 80W–90W gear oil until it just reaches the fill plug. (Fig. 5.7)

5.2 TROUBLESHOOTING

Should any problems arise review the troubleshooting procedures in this section to find the possible problem or fix and adjust your machine.

For spare parts view the procedure for ordering as layed out on the first page of the spare parts section.

Symptom	Possible Cause	Possible Solution
Machine does not start or a breaker trips.	<ol style="list-style-type: none"> 1. Stop push-button engaged/faulty. 2. Power switched OFF or at fault. 3. Thermal overload relay has tripped. 4. Wall circuit breaker tripped. 5. Plug/receptacle at fault/wired incorrectly. 6. Motor connection wired incorrectly. 7. Contactor not energized. 8. Wiring open/has high resistance. 9. ON/OFF switch at fault. 10. Start capacitor at fault. 11. Centrifugal switch at fault 12. Motor at fault. 	<ol style="list-style-type: none"> 1. Check magnetic switch/replace it. 2. Ensure power supply is switched ON 3. Reset trip load dial if necessary; replace. 4. Ensure circuit size is correct/replace. 5. Test for good contacts; correct the wiring. 6. Correct motor wiring connections 7. Test all legs for power/replace if faulty. 8. Check and fix broken, disconnected wires 9. Replace switch. 10. Test/replace if faulty. 11. Adjust/replace centrifugal switch. 12. Test/repair/replace.
Machine stalls or is underpowered	<ol style="list-style-type: none"> 1. Feed rate too fast. 2. Workpiece material not suitable. 3. Dust collection ducting problem. 4. Motor overheated. 5. V-belt(s) slipping. 6. Run capacitor at fault. 7. Pulley/sprocket slipping on shaft. 8. Motor bearings at fault. 9. Motor at fault. 	<ol style="list-style-type: none"> 1. Decrease feed rate. 2. Ensure timber moisture is below 20%. 3. Clear blockages, use smooth wall duct, 4. Clean motor, let cool, and reduce load. 5. Tension/replace belt(s) ensure pulleys are aligned 6. Test/repair/replace. 7. Replace loose pulley/shaft. 8. Test/repair/replace. 9. Test/repair/replace.
Excessive step (snipe) (gouge at the end of the workpiece that is uneven with the rest of the cut).	<ol style="list-style-type: none"> 1. One or both of the bed rollers are set too high. 2. Rear table extension slopes down or is not level with the table 3. Chip breaker or pressure bar set too low 4. Workpiece is not fully supported as it leaves the thicknesser. 	<ol style="list-style-type: none"> 1. Lower the bed rollers 2. Adjust the rear extension wing set screws to make the extension level with the table 3. Raise the height of the chip breaker or pressure bar 4. Use a roller stands to properly support the workpiece as it leaves the thicknesser.
Workpiece stops/slow in the middle of the cut.	<ol style="list-style-type: none"> 1. Depth of cut too deep. 2. Pitch/glue build-up on thicknesser components. 3. Bed rollers are not set to correct height. 4. Chip breaker or pressure bar set too low 5. Feed rollers set too low or too high 	<ol style="list-style-type: none"> 1. Reduce the depth of cut. 2. Clean planer components with a pitch/resin dissolving solvent. 3. Lower/raise the bed rollers. 4. Raise the height of the chip breaker or pressure bar 5. Adjust the feed rollers to the correct height

5.2 TROUBLESHOOTING Cont.

Symptom	Possible Cause	Possible Solution
Machine has vibration or noisy operation.	<ol style="list-style-type: none"> 1. Belts slapping cover. 2. V-belt(s) worn or loose. 3. Pulley loose. 4. Motor mount loose/broken. 5. Motor fan rubbing on fan cover. 6. Table rollers protruding unevenly. 7. Motor bearings at fault. 8. Cutterhead bearings at fault. 9. Chip deflector hitting cutterhead. 	<ol style="list-style-type: none"> 1. Replace/realign belts with a matched set. 2. Inspect/replace belts with a new matched set. 3. Realign/replace shaft, pulley, setscrew, & key. 4. Tighten/replace. 5. Fix/replace fan cover; replace damaged fan. 6. Adjust table rollers. 7. Test by rotating shaft; & replace worn bearings 8. Replace bearing(s)/realign cutterhead. 9. Check/replace chip deflector and realign
Consistent chipping pattern.	<ol style="list-style-type: none"> 1. Knots or conflicting grain direction in workpiece. 2. Nicked or chipped cutter or insert. 3. Feed rate too fast. 4. Depth of cut too deep. 5. Bed rollers set too high or low; not even with each other. 6. Misaligned chip breaker. 	<ol style="list-style-type: none"> 1. Inspect workpiece for knots and grain direction; use only clean stock. 2. Rotate/replace cutters or insert . 3. Reduce feed rate. 4. Reduce the depth of cut. 5. Properly adjust the bed roller height. 6. Adjust sides of chip breaker until correct
Furry grain.	<ol style="list-style-type: none"> 1. Workpiece has high moisture content or surface wetness. 2. Dull cutter blades or inserts 	<ol style="list-style-type: none"> 1. Allow workpiece to dry if moisture contents over 20% or has surface wetness. 2. Rotate/replace cutter blades or inserts
Lines or ridges running the length of the workpiece	<ol style="list-style-type: none"> 1. Nicked blades or chipped inserts. 	<ol style="list-style-type: none"> 1. Rotate or replace the inserts or replace the damaged blades.
Uneven cutting marks, wavy surface, or chatter marks on the workpiece.	<ol style="list-style-type: none"> 1. Feed rate too fast. 2. Chip breaker or pressure bar set unevenly. 3. Bed rollers not set correctly. 4. Insert(s) or blades not properly installed. 5. Worn cutterhead bearings. 	<ol style="list-style-type: none"> 1. Reduce feed rate. 2. Adjust the height of the chip breaker or pressure bar 3. Properly adjust the bed roller height 4. Remove insert(s) or blades, then properly clean and install 5. Replace cutterhead bearings
Glassy surface	<ol style="list-style-type: none"> 1. Inserts are dull. 2. Feed rate too slow. 3. Depth of cut too shallow 	<ol style="list-style-type: none"> 1. Rotate/replace inserts or replace blades 2. Increase feed rate 3. Increase depth of cut
Inconsistent chip marks.	<ol style="list-style-type: none"> 1. Chips are not being removed from around the cutterhead 	<ol style="list-style-type: none"> 1. Use an adequate dust collection system; adjust the chip deflector in or out.

6. ADJUSTMENTS

6.1 REPLACING CUTTER BLADES

The height of the knives that have been correctly set is crucial to the thicknesser optimum performance. It is very important to keep the knives sharp, and the height of each blade the same. If one blade protrudes higher than the others, it will take most of the load and will dull much faster, and the result will be a poor finish.

As part of the accessories the knife-setting jig is included

To adjust height of blades or replace them:

1. DISCONNECT THE MACHINE FROM POWER!
2. Remove headstock cover to expose the cutter head. Remove the six screws (A), and remove the upper cover (B) as shown in Fig. 6.1.
3. The blades are very sharp so use heavy leather gloves when handling the blades.
4. Remove the upper belt cover, then rotate the cutterhead pulley to provide access to one of the blades.
5. Loosen the cutterhead gib bolts until the blade is completely loose. If the blades are to be replaced, remove the old blade and install the new one, making sure the bevelled edge of the new knife is facing the correct direction. (Fig.6.2)
6. Position the blade setting jig over the blade so that blade edge is directly under center pad, as shown in Fig. 6.3
7. Insert a hex wrench into jack screws through access holes in cutterhead. Rotate the jack screws to raise or lower the blade until it barely touches center pad of knife-setting jig with all legs of jig still firmly on cutterhead, then tighten the gib bolts enough to firmly hold the blade in place without fully tightening gib bolts.
8. Incrementally tighten the gib bolts in an even manner, starting at middle and working your way to the ends by alternating left and right.
9. Repeat Step 8, tightening the gib bolts a little more.
10. Repeat Step 8, this time fully tightening all the gib bolts.
11. Repeat Steps 4–8 for remaining knives.

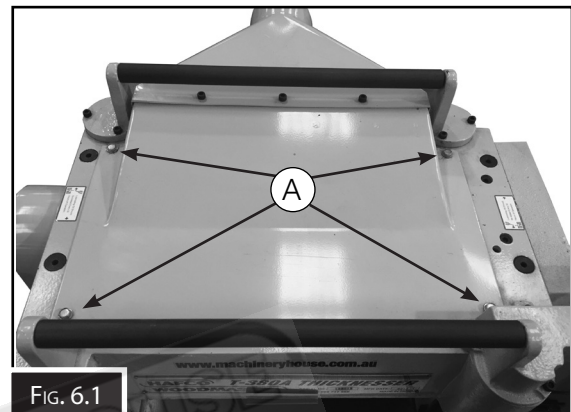

FIG. 6.1

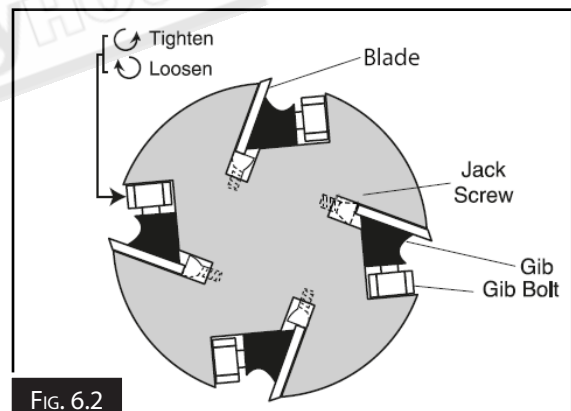

FIG. 6.2

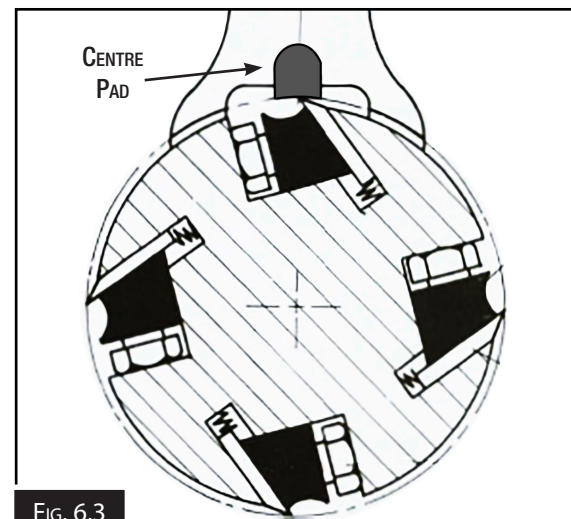

FIG. 6.3

6.2 REPLACING INSERT TYPE CUTTERS

Some models are supplied with a spiral cutterhead equipped with indexable carbide inserts. As they wear they can be rotated to one of their four cutting edges. If one edge of the insert becomes dull or damaged, simply rotate it 90° to reveal a fresh cutting edge. (Fig. 6.4)

The models fitted with the spiral carbide insert cutters are listed below, however the cutters can be purchased as an optional replacement.

T-380S
T-20S

To change or rotate a spiral cutterhead inserts:

1. DISCONNECT MACHINE FROM THE POWER!
2. Remove the dust hood, belt cover, and the top cover.
3. Leather heavy gloves should be worn to protect your hands and fingers.
4. Remove any sawdust or debris from around the insert, Torx screw, and the surrounding area.
5. Remove the Torx screw and the insert, then clean both parts and the pocket where the insert sits.

Note: Ensure the insert, Torx, screw, and the cutter head pocket have been thoroughly cleaned. This is critical to achieving a smooth and precision finish.

If dirt or dust is trapped between the insert and cutterhead it will slightly raise the insert, and make noticeable marks.

6. Replace the insert so that a fresh cutting edge faces outward. If all four insert cutting edges have been used, replace the insert with a new one. Always position the reference mark (Fig.6.5) on the insert in the same position when installing a new insert to aid in the rotational sequencing.
7. Lubricate the Torx screw threads with a very small amount of light machine oil, wipe the excess off, and tighten the screws making sure not to over tighten them.

Note: Do Not use too much oil. The excess may squeeze out of the threaded hole as you install the insert and force the insert to raise slightly, forcing the insert out of alignment.

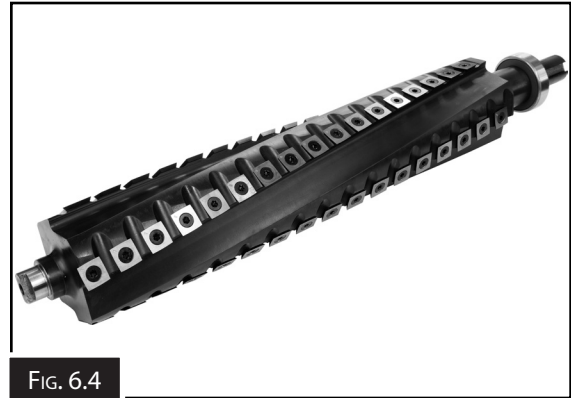

FIG. 6.4

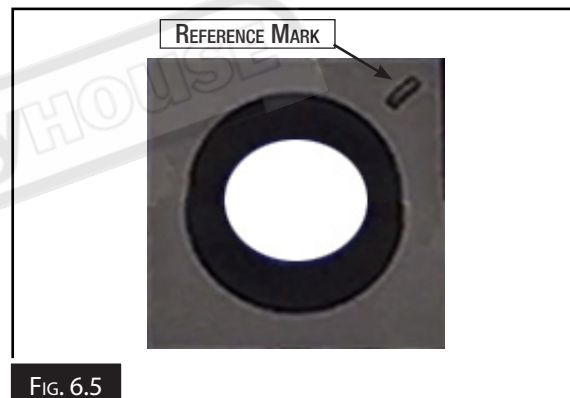

FIG. 6.5

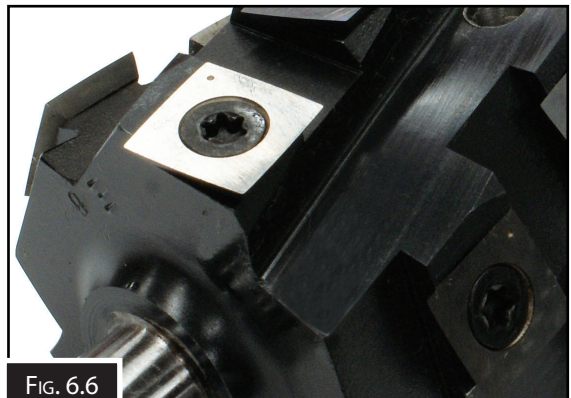

FIG. 6.6

6.2 TENSIONING AND REPLACING DRIVE BELTS

Three V-belts transfer power from the motor to the cutterhead, and then through the gear-box and drive chains to the infeed and outfeed rollers. To ensure efficient transfer of power to these systems, make sure the V-belts are always properly tensioned and in good condition.

If a V-belt is worn, cracked, or damaged, then replace all three V-belts at the same time with matched V-belts to ensure belt tension is even among the belts.

To Tension Or Replace The V-Belts:

1. DISCONNECT THICKNESSER FROM POWER!
2. Remove the V-belt cover from the left side of the machine to expose the belts.
3. Remove the front cabinet panel to access the motor.
4. If the V-belts need to be replaced, raise the motor to release the belt tension, roll them off the pulleys, then replace them as a matched set of three.
5. To adjust the V-belt tension, loosen the top motor mount hex nuts (Fig. 6.7), then adjust the bottom hex nuts to raise or lower the motor.

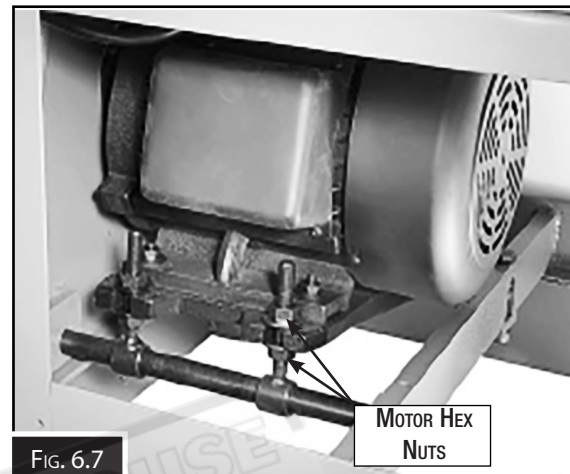

FIG. 6.7

Note: The V-belts are correctly tensioned when there is approximately 20mm deflection when moderate pressure is applied to them midway between the pulleys. (Fig. 6.8)

6. When the V-belts are correctly tensioned, make sure the motor mount hex nuts are tight, then replace the cabinet cover and the belt cover.

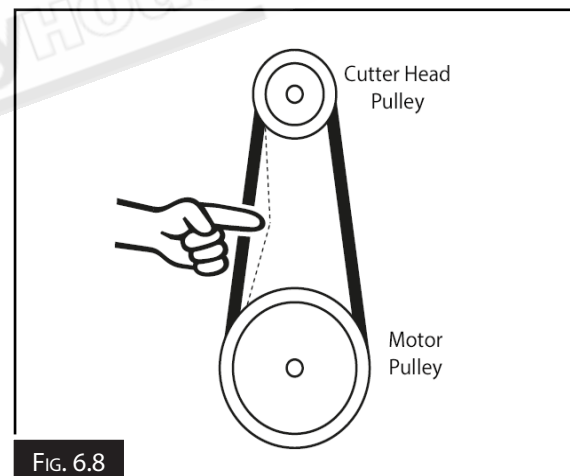

FIG. 6.8

TABLE HEIGHT CHAIN TENSION

The table height chain transfers movement from the handwheel to elevate the table. This chain can be adjusted to remove slack if it stretches over time or is loosened during table levelling procedures.

To adjust the table height chain tension:

1. DISCONNECT MACHINE FROM POWER!
2. Remove the front and rear cabinet panels to gain access to the table height chain system underneath the table. (Fig 6.9)
3. Loosen the lock bolts shown, and push the idler sprocket against the chain with moderate hand pressure, then while maintaining the pressure, re-tighten both lock bolts.

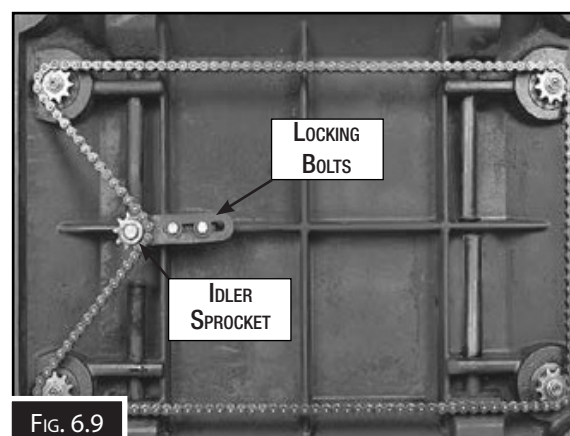

FIG. 6.9

6.3 ADJUSTING HEIGHT OF IN-FEED ROLLER, CHIPBREAKER, PRESSURE BAR & OUT-FEED ROLLER

The machine operates at its optimum when the feed rollers, chip breaker, and pressure bar are set at the correct distance below the cutter head allowing the workpiece to move through the thicknesser evenly and at the correct distance from the cutter head.

The in-feed roller, chipbreaker, pressure bar and out-feed roller are adjusted at the factory. The in-feed roller and the chipbreaker are set 0.1mm below the cutting circle, the pressure bar is set 0.2mm below the cutting circle and the out-feed roller is set 0.5mm below the cutting circle, as shown in Fig. 6.10.

To ensure accurate results and make the adjustment process quicker, we recommend using a dial indicator.

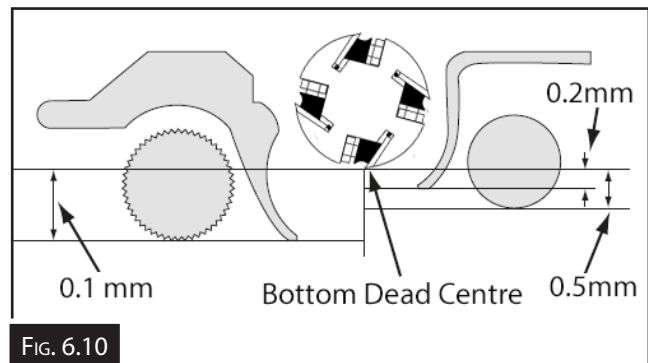

FIG. 6.10

1. DISCONNECT THICKNESSER FROM THE POWER SUPPLY!
2. Lower the table at least 100mm below the head casting, then lock it in place.
3. Remove the dust hood, top cover, and belt cover.
4. Using a dial indicator as shown in Fig. 6.11, find the bottom dead centre of any blade edge by slowly rocking the cutterhead pulley back and forth until the dial indicator finds the lowest point, then set the dial indicator to zero.
5. Move the feed speed knob to the neutral position to allow the in-feed roller to freely rotate.
6. Keeping the dial indicator at zero, position it under the right-hand side of the in-feed roller and find the BDC of a serrated edge by rocking the in-feed roller back and forth.
7. Loosen the lock nut and move the set screw (Fig.6.12) to adjust the height of the in-feed roller bushing block until the dial indicator shows 0.1mm, which is the recommended distance for the in-feed roller below the cutter head.
8. Repeat Steps 6–7 on the opposite side of the in-feed roller.
9. Re-check both sides of the in-feed roller and, if necessary, make further adjustments, then re-tighten both lock nuts.
10. Keeping the same zero reference on the dial indicator from Step 5, repeat Steps 7–10 for the out-feed roller, but adjust it until it is 0.5mm below the BDC of the cutter head blade.

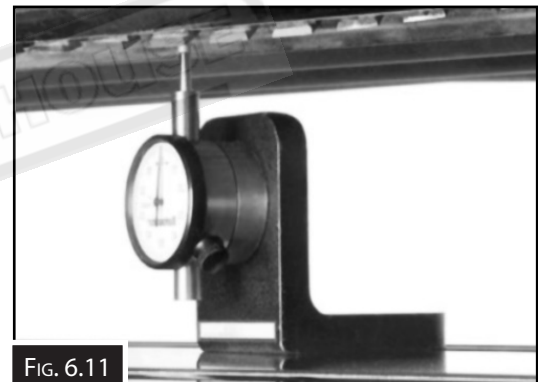

FIG. 6.11

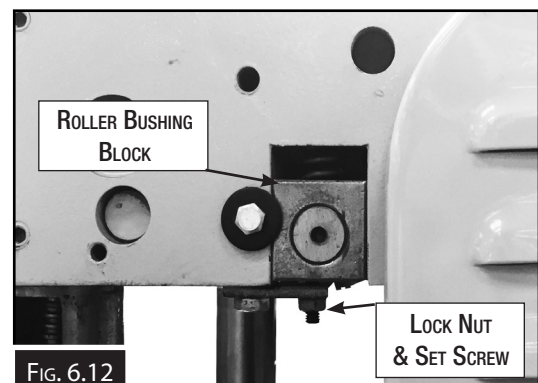

FIG. 6.12

- Use the same zero reference on the dial indicator from Step 5, perform similar steps as described above to adjust the height of the chip breaker to its recommended specification given at the beginning of this subsection.

The adjustment controls are shown in Fig. 6.13

- Re-install the belt cover, top cover, and the dust hood.

6.4 ADJUSTING KICKBACK FINGERS

An important safety feature of your thicknesser are the anti-kickback fingers. The fingers are suspended from a rod across the head casting and in front of the in-feed roller, (Fig. 6.14). These fingers allow the workpiece to enter the thicknesser but reduces the risk of kickback by digging into the workpiece if it moves backward.

The anti-kickback fingers need to be regularly checked to make sure that they move freely. If they do not move easily then clean them with a solvent, and inspect them for any damage. If any are damaged, they must be replaced before the machine is used again.

Oil or other lubricants must not be placed on the anti-kickback fingers. Lubricants will attract dust and restrict the free movement of the fingers.

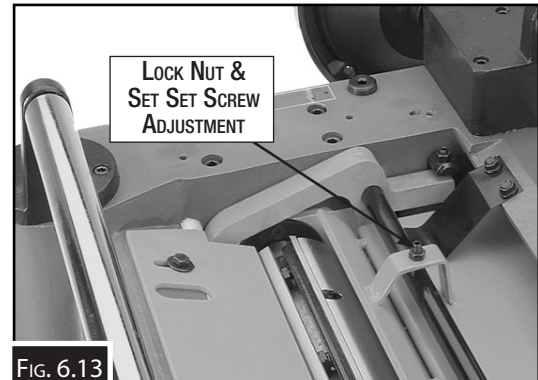

FIG. 6.13



FIG. 6.14

6.5 POSITIONING THE CHIP DEFLECTOR

When properly distanced from the cutterhead, the chip deflector keeps chips from falling onto the outfeed roller and being pressed into the workpiece.

To adjust

- DISCONNECT THE THICKNESSER FROM POWER!
- Remove the dust chute, belt cover, and top cover,.
- Rotate the cutterhead pulley until a blade of the cutter head is nearest the chip deflector, then measure that distance between the chip deflector and the blade. (Fig. 6.15).

If the distance measured in Step 3 is not 6mm then loosen the four hex bolts that secure the chip deflector and adjust the gap to 6mm.

- Repeat Step 3 for the other end of the cutter head.
- Re-tighten the hex bolts, then replace the belt cover, top cover, and dust hood.

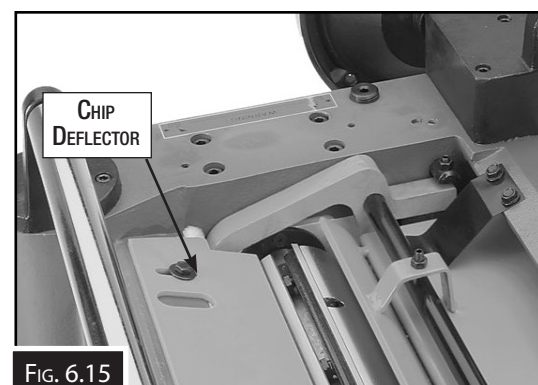

FIG. 6.15

6.6 SETTING DIGITAL READOUT

The machines are fitted with a digital height gauge (Fig.6.16) which needs to be set before the machine is used. Once the digital display is set and switched off the settings will be stored ready for the next time the display is switched on. Re-setting should only be needed if the battery is changed. The display can read in either “mm” or inches. (Battery is LR-44)

To set the display

1. Switch the display “ON.”
2. Plane a piece of wood and measure its thickness, do not move the hand wheel after this.
3. Press the “SET” button and hold for approx. 2 seconds until the “+” sign starts flashing on the screen.
4. To change the “+” to a “-” (if required – otherwise go to step 4.), press the “SET” button once.
5. Press the “SET” button and hold for approx. 2 seconds until the 1st digit starts flashing on the screen.
6. To change the 1st digit, press the “SET” button. Every time you press the “SET” button, the 1st digit will increase by 1.
7. To move across to the second digit press and hold the set button for 2 secs. until the second digit flashes. Every time you press the “SET” button, the 2nd digit will increase by 1. Continue to move across the digits by holding the “SET” button for 2 secs. until completed.
8. Press the “SET” button once more to complete.



FIG. 6.16

The DRO should now be set to display the thickness of the wood as planned.

ABS BUTTON

The digital display allows for a switching between “Absolute” and “Incremental” measurement.

How to use the “ABS” button.

EXAMPLE

If the screen displays 100mm, when the ABS button is pressed the display is changed to “Zero” and “INC” is displayed on the screen. If the table is now lowered 10mm then -10mm is display. When the ABS button is pressed again then the screen will display 90mm (the 100mm less the 10mm)

The incremental setting can be used as many times as is needed without losing the absolute measurement.



FIG. 6.16

SPARE PARTS SECTION

THICKNESSER

Models

T-380, T-380S, T-20, T-20A, T-20S

Order Code W414, W414S, W415, W415A, W415S

EDITION No : TH-003
DATE OF ISSUE : 01/2024

The following section covers the spare parts diagrams and lists that were current at the time this manual was originally printed. Due to continuous improvements of the machine, changes may be made at any time without notification.

HOW TO ORDER SPARE PARTS

1. Have your machines **model number, serial number & date of manufacture** on hand, these can be found on the specification plate mounted on the machine
2. A scanned copy of your parts list/diagram with required spare part/s identified.

NOTE: SOME PARTS MAY ONLY BE AVAILABLE AS AN ASSEMBLY

3. Go to www.machineryhouse.com.au/contactus and fill out the inquiry form attaching a copy of scanned parts list.

CONTENTS

Parts Diagram For W414 & W414S.....	32
Parts List For W414 & W414S.....	33
Parts Diagram For W415, W415A & W415S.....	36
Parts List For W415, W415A & W415S.....	37
Risk Assessment.....	41

PARTS FOR W414 & W414S

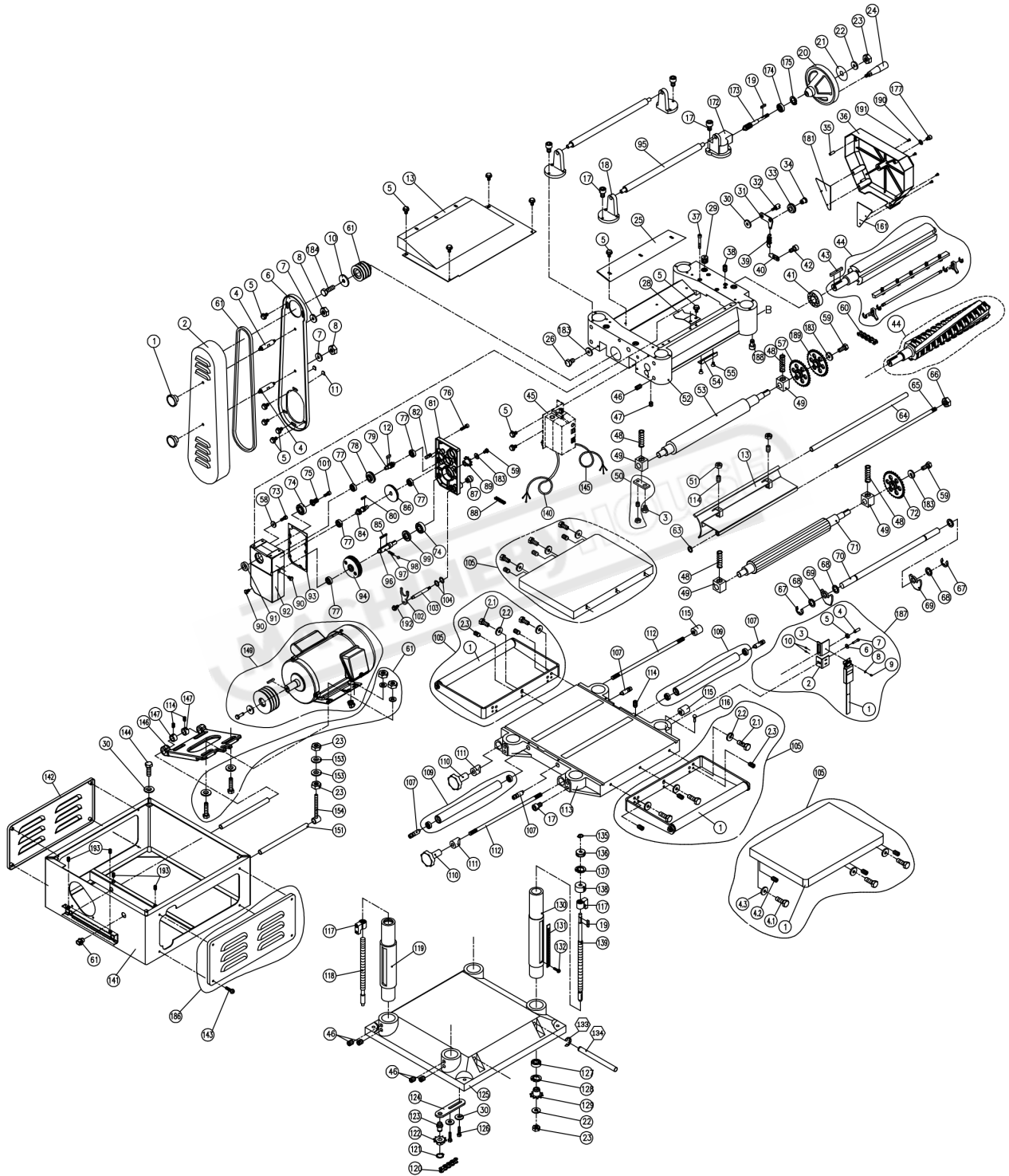

PARTS LIST FOR W414 & W414S

Item	Part Number	Description	Specification	Qty.
1	230118-000	NUT		2
2	170417-000	BELT HOUSING		1
3	014003-000	BELT	M40	3
4	380147-901	BOLT	M6*1.0P*12	2
5	000902-202	HEX SCREW W/ WASHER		26
6	170418-000	PULLEY COVER		1
7	006002-046	FLAT WASHER	8.5*16*1.5t	2
8	009005-200	HEX NUT	5/16"-18NC(12.7B*6.75H)	2
9	000003-204	HEX SCREW	M8*1.25P*20	4
10	006001-043	FLAT WASHER	8.2 *30*4.0t	1
11	200013-615	PLATE		2
12	012003-003	KEY	5*5*12	1
13	920351-000	UPER COVER		1
17	000103-107	CAP SCREW	M6*1.0P*20	19
18	050288-000	ROLLER BRACKET		3
19	012002-004	KEY	4*4*10	1
20	240015-000	HANDWHEEL		1
22	006002-067	FLAT WASHER	10*20*1.5t	4
23	008008-200	HEX NUT	10*1.25P(17B*8H)	6
25	250158-617	CHIP DEFLECTOR		1
26	000002-101	HEX SCREW	M6*1.0P*12	4
27	006001-056	FLAT WASHER	8.5*23*2.0t	8
28	270015-901	SPRING PLATE		3
29	380200-901	SCREW		4
30	006001-041	FLAT WASHER	8.2*22*3.0t	3
31	170405-901	BRACKET		1
32	290039-901	SHAFT		1
33	130071-000	TENSION WHEEL		1
34	360349-902	SHAFT	6*20	1
35	011004-102	SPRING PIN		2
36	050276-000	COVER		1
37	000104-114	CAP SCREW	M8*1.25P*50	4
38	000203-106	SET SCREW	M6*1.0P*16	5
39	280050-000	SPRING		1
40	170406-901	HANGER		1
41	033706-000	NBALL BEARING	6205-NKE	1
42	000103-102	CAP SCREW	M6*1.0P*10	2
43	012204-001	KEY	8*8*36	1
44	922025-000	CUTTERHEAD (MODEL T-380S)	SPIRAL	1
44	922355-000	CUTTERHEAD (MODEL T-380)	FLAT	1
45	937737-000	MAG SWITCH (MODEL T-380S)	3HP 240V 1PH	1
45	937002-000	MAG SWITCH (MODEL T-380)	2HP 240V 1PH	1
46	000205-101	SET SCREW	M10*1.5P*12	15
47	000204-103	SET SCREW	M8*1.25P*12	1
48	280051-000	SPRING		4
49	130039-000	BUSHING		4
50	170408-902	PLATE		4

PARTS LIST FOR W414 & W414S

Item	Part Number	Description	Specification	Qty.
51	008005-200	HEX NUT		6
52	050282-000	HEAD CASTING		1
53	360383-000	OUTFEED ROLLER		1
54	170409-901	DEPTH LIMITER		1
55	000402-202	FLAT HD SCREW	M5*0.8P*8	2
56	012202-001	KEY	5*5*22	2
57	070012-000	SPROCKET		1
58	006001-020	FLAT WASHER	6.2*20*3.0t	1
59	000002-203	HEX SCREW	M6*1.0P*16	3
60	016306-000	CHAIN	#06B*63P	1
61	920488-000	MOTOR PULLEY		1
63	010003-000	S-CLIP	STW-12	1
64	360351-000	ADJUST ROD		1
65	360366-902	LOCKING ROD		1
66	008009-200	HEX NUT	M12*1.75P(19B*10H)	1
67	010209-000	E-CLIP	ETW-15	2
68	250160-615	COLLAR		40
69	172281-905	ANTI-KICKBACK FINGER		39
70	360352-000	SHAFT		1
71	360353-000	INFEED ROLLER		1
72	070013-000	SPROCKET		1
73	000103-103	CAP SCREW	M6*1.0P*12	1
74	030109-000	BALL BEARING	6204-ZZ	1
75	320196-000	GEAR		1
76	000103-108	CAP SCREW	M6*1.0P*25	6
77	030701-000	BALL BEARING	6201	2
78	320197-000	GEAR		1
79	320160-000	GEAR AND SHAFT		1
80	012003-002	KEY	5*5*10	1
81	050280-000	GEAR CASE		1
82	360355-901	PIN		2
83	030304-000	BALL BEARING	6201Z(A)	3
84	320205-000	SHAFT		1
85	012004-003	KEY	6*6*40	1
86	320198-000	GEAR		1
87	250372-615	KNOB		1
88	016303-000	CHAIN	#06B*47P	1
89	150008-000	SPROCKET		1
90	043401-000	OIL PLUG	PT1/4"-19	2
91	043608-000	OIL SEAL	TC28*40*8	1
92	050281-000	GEAR BOX		1
93	340012-615	GASKET		1
94	922351-000	DOUBLE GEAR		1
95	360375-902	ROLLER		2
96	360357-901	SHAFT		1
97	280052-000	SPRING		1
98	017002-000	BALL	6	1
99	043505-000	OIL SEAL	SC25*47*6	1
100	030306-000	BALL BEARING	6204Z(A)	1

PARTS LIST FOR W414 & W414S

Item	Part Number	Description	Specification	Qty.
102	070014-000	SHIFTER		1
103	360358-901	SHIFTING SHAFT		1
104	043303-000	O-RING	P12	1
105	922365-000	ROLLER ASSEMBLY		2
	170422-008	BRACKET		1
	190044-906	ROLLER		1
	360370-901	SHAFT		1
	250251-615	BUSHING		2
	000002-201	HEX SCREW	M6*1.0P*12	2
	006002-034	FLAT WASHER	6.7*16*2.0t	2
	520001-237	BOX	410*285*55	1
106	041503-017	PLASTIC PLATE	570*440*0.05t	1
107	360360-902	SHAFT		4
109	921209-000	ROLLER		2
110	230115-000	NUT		2
111	130037-000	GIB BOLT		2
112	360350-902	LEAD SCREW		2
113	050283-000	MIDDLE TABLE		1
114	000203-104	SET SCREW	M6*1.0P*12	11
115	130038-000	GIB BOLT		2
116	002301-201	RIVET	2*5	2
117	130043-000	NUT		4
118	360359-000	SHORT LEADSCREW		3
119	050284-000	COLUMN		3
120	016220-000	CHAIN	#410*134P	1
121	010006-000	S-CLIP	STW-15	1
122	150009-000	SPROCKET		1
123	360362-902	SHAFT		1
124	170413-901	BRACKET		1
125	050285-000	BASE		1
126	000003-205	HEX SCREW	M8*1.25P*25	2
127	030305-000	BALL BEARING	6202Z(A)	4
128	010103-000	R-CLIP	RTW-35	4
129	150010-000	SPROCKET		4
130	050286-000	COLUMN		1
131	570889-000	SCALE		1
132	000301-201	SCREW	M3*0.5P*6	2
133	010208-000	E-CLIP	ETW-12	4
134	360367-902	LIFT SHAFT		4
135	010001-000	S-CLIP	STW-10	1
136	320201-000	GEAR		1
137	010104-000	R-CLIP	RTW-38	1
138	130041-000	BUSHING		1
139	360372-000	LONG LEADSCREW		1
141	170420-000	STAND		1
142	170421-000	PANEL		1
143	000403-204	SCREW	M6*1.0P*20	8
144	000003-109	HEX SCREW	M8*1.25P*45	4
146	050287-008	MOTOR MOUNT		1

PARTS FOR W415, W415A & W415S

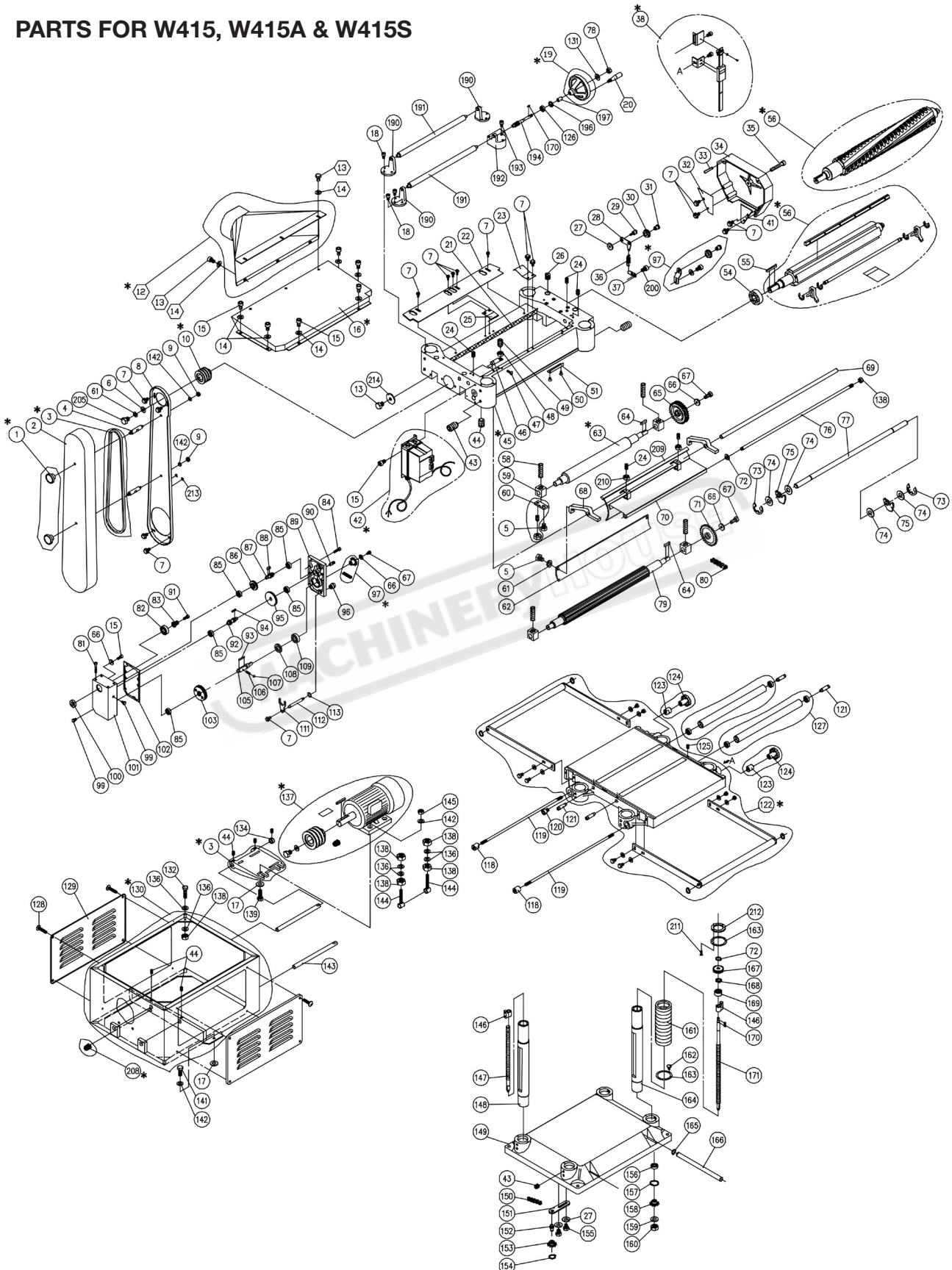

PARTS LIST FOR W415, W415A & W415S

Item	Part Number	Description	Specification	Qty.
1	230118-000	NUT		2
2	170431-000	PULLEY COVER		1
3	014010-000	BELT	M59	3
4	380147-901	BOLT		2
5	000003-204	HEX SCREW	M8*1.25P*20	6
6	006001-043	FLAT WASHER	8.2(+0.2/-0)*30*4.0t	2
7	000902-202	HEX SCREW WITH WASHER	M6*1.0P*12	15
8	170432-000	PULLEY GUARD		1
9	009005-200	HEX NUT	5/16"-18NC(12.7B*6.75H)	2
10	050273-901	CUTTERHEAD PULLEY		1
12	920265-000	COLLECTOR TUBE		1
13	000002-201	HEX SCREW	M6*1.0P*12	4
14	006002-032	FLAT WASHER	6.6*13*1.0t	7
15	000103-103	CAP SCREW	M6*1.0P*12	9
16	170494-000	UPPER COVER		1
17	006001-056	FLAT WASHER	8.5*23*2.0t	10
18	000103-106	CAP SCREW	M6*1.0P*16	9
19	920263-000	HANDWHEEL		1
21	200021-000	SPONGE		1
22	250172-617	CHIP DEFLECTOR		1
23	270015-901	PLATE SPRING		3
24	000203-106	SET SCREW	M6*1.0P*16	9
25	270017-901	PLATE SPRING		1
26	380200-901	SCREW		4
27	006001-041	FLAT WASHER	8.2*22*3.0t	3
28	170405-901	BRACKET		1
29	290039-901	SHAFT		1
30	130071-000	IDLE PULLEY		1
31	360349-902	SHAFT		1
32	170473-904	SAFETY HATCH		1
33	011004-102	SPRING PIN	6*20	2
34	050292-000	COVER		1
35	000104-112	CAP SCREW	M8*1.25P*40	1
36	280050-000	SPRING		1
37	170406-901	HANGER		1
38	921246-000	DIGITAL READOUT		1
39	006002-046	FLAT WASHER	8.5*16*1.5t	2
41	170475-904	SAFETY		1
42	937009-000	MAG SWITCH (MODEL T-20)	3HP*240V*50HZ*1PH	1
42	937461-000	MAG SWITCH (MODEL T-20)	5HP*415V*50HZ*3PH	1
42	937738-000	MAG SWITCH (MODEL T-20S)	5HP*415V*50HZ*3PH	1
43	000205-101	SET SCREW	M10*1.5P*12	15
44	000204-103	SET SCREW	M8*1.25P*12	6
45	050293-000	CASTING HEAD		1
46	360385-901	SHAFT		2
47	002301-201	RIVET	2*5	4
48	008005-200	HEX NUT	M6*1.0P(10B*5H)	6
49	000203-107	SET SCREW	M6*1.0P*20	2
50	000402-202	FLAT HEAD MACHINE SCREW	M5*0.8P*8	2

PARTS LIST FOR W415, W415A & W415S

Item	Part Number	Description	Specification	Qty.
51	170409-901	CUT LIMITER PLATE		1
54	033705-000	BALL BEARING	6206-2NKE	1
55	012204-001	KEY	8*8*36	1
56	920734-000	CUTTERHEAD (MODEL T-20)	FLAT	1
56	922045-000	CUTTERHEAD (MODEL T-20S)	SPIRAL	1
58	280051-000	SPRING		4
59	130039-000	BUSHING		4
60	170408-902	PLATE		4
61	006305-100	LOCK WASHER	8.2*15.4	3
62	170477-019	PRESSURE PLATE		1
63	360405-000	OUTFEED ROLLER		1
64	012003-008	KEY	5*5*22	2
65	070012-000	SPROCKET		1
66	006001-020	FLAT WASHER	6.2*20*3.0t	4
67	000002-203	HEX SCREW	M6*1.0P*16	3
68	070016-025	BRACKET		2
69	360386-000	SHAFT		1
70	170478-000	CHIP BREAKER		1
71	070013-000	SPROCKET		1
72	010003-000	RETAINING RING	STW-12	2
73	010209-000	RETAINING RING	ETW-15	2
74	250160-615	COLLAR		56
75	172281-905	ANTI-KICKBACK FINGER		55
76	360387-000	LOCKING BOLT		1
77	360388-000	SHAFT		1
78	008009-200	HEX NUT	M12*1.75P(19B*10H)	2
79	360389-000	INFEED ROLLER		1
80	016308-002	CHAIN	#06B*67P	1
81	000104-114	CAP SCREW	M8*1.25P*50	4
82	030109-000	BALL BEARING	6204-ZZ	1
83	320196-000	GEAR		1
84	000103-108	CAP SCREW	M6*1.0P*25	5
85	030701-000	BALL BEARING	#6201	2
86	320197-000	GEAR		1
87	320160-000	SHAFT		1
88	012003-003	KEY	5*5*12	1
89	050280-000	COVER		1
90	360355-901	PIN		2
92	320205-000	SHAFT		1
93	012004-003	KEY	6*6*40	1
94	012003-002	KEY	5*5*10	1
95	320198-000	GEAR		1
96	250372-615	HANDLE		1
97	920744-000	SPROCKET & CHAIN ASSY	16/20FPM	1
99	043401-000	OIL PLUG	PT1/4"-19	2
100	043608-000	OIL SEAL	TC28*40*8	1
101	050281-000	WORM GEAR BOX		1
102	340012-615	GASKET		1
103	922351-000	GEAR		1

PARTS LIST FOR W415, W415A & W415S

Item	Part Number	Description	Specification	Qty.
104	000902-203	HEX SCREW WITH WASHER	M6*1.0P*16	5
105	360357-901	SHAFT		1
106	280052-000	SPRING		1
107	017002-000	BALL	6mm	1
108	043505-000	OIL SEAL	SC25*47*6	1
109	030306-000	BALL BEARING	6204Z(A)	1
111	070014-000	CLUTCH		1
112	360358-901	SHAFT		1
113	043303-000	OIL RING	P12	1
114	041503-018	PLASTIC PLATE	720*570*0.05t	1
118	130038-000	LOCKING BAR		2
119	360390-000	LOCKING BOLT		2
120	000104-104	CAP SCREW	M8*1.25P*16	7
121	360391-000	ECCENTRIC SHAFT		4
122	922032-000	EXTENSION ROLLER ASSY.		1
1.1	050294-000	MIDDLE TABLE		1
1.2	920746-000	ROLLER ASSY		2
1.3	850399-000	EXTENSION HARDWARE		1
116	000004-202	HEX SCREW	M10*1.5P*25	8
117	006001-095	FLAT WASHER	13.5*32*2.3t	8
183	041103-001	PLASTIC BAG	120*100*0.1t	1
123	130037-000	LOCKING BAR		2
124	230115-000	KNOB		2
125	000203-104	SET SCREW	M6*1.0P*12	4
126	030304-000	BALL BEARING	6201Z(A)	4
127	921208-000	ROLLER		2
128	000403-204	SCREW	M6*1.0P*20	8
129	170479-000	COVER		2
130	170480-000	MOTOR MOUNT		1
131	006002-091	FLAT WASHER	13*28*3.0t	13
132	000005-202	HEX SCREW	M12*1.75P*50	4
134	190074-901	COLLAR		1
137	900025-000	MOTOR ASSY (MODEL T-20)	3HP*240V*50HZ*1PH	1
137	900018-000	MOTOR ASSY (MODEL T-20)	5HP*415V*50HZ*3PH (160)	1
137	901135-000	MOTOR ASSY (MODEL T-20S)	5HP*415V*50HZ*3PH (190)	1
138	008009-100	HEX NUT	M12*1.75P(19B*10H)	8
139	000003-208	HEX SCREW	M8*1.25P*40	4
141	000003-106	HEX SCREW	M8*1.25P*30	2
142	006001-046	FLAT WASHER	8.5*16*1.5t	6
143	360394-000	SUPPORT SHAFT		2
144	380249-901	ADJUSTING BOLT		2
145	008006-200	HEX NUT	M8*1.25P(13B*6.5H)	4
146	130045-000	NUT		4
147	360395-000	LEAD SCREW (SHORT)		3
148	050296-000	COLUMN		3
149	050297-000	BASE		1
150	016004-000	CHAIN	#40*166P	1
151	170413-901	BRACKET		1
152	360362-902	SHAFT		1

PARTS LIST FOR W415, W415A & W415S

Item	Part Number	Description	Specification	Qty.
153	150011-000	SPROCKET		1
154	010006-000	RETAINING RING	STW-15	1
155	000003-205	HEX SCREW	M8*1.25P*25	1
156	030305-000	BALL BEARING	6202Z(A)	4
157	010103-000	RETAINING RING	RTW-35	4
158	150012-000	SPROCKET		4
159	006001-078	FLAT WASHER	10.5*19*1.5t	4
160	008008-100	HEX NUT	M10*1.25P(17B*8H)	4
161	250173-615	EXPANSION BEND		8
162	001104-502	SCREW	M5*2.12P*10	30
163	170481-901	RING		16
164	050298-000	COLUMN		1
165	010202-000	RETAINING RING	ETW-17	4
166	360396-902	LIFT SHAFT		4
167	320203-000	GEAR		1
168	010104-000	RETAINING RING	RTW-38	1
169	130046-000	BUSHING		1
170	012002-004	KEY	4*4*10	2
171	360397-000	LEAD SCREW (LONG)		1
172	021306-000	STRAINING RELIEF	PGA16-14B	1
190	050299-000	ROLLER STAND		3
191	360398-902	ROLLER		2
192	050300-000	WORM GEAR		1
193	000103-113	CAP SCREW	M6*1.0P*50	3
194	320204-000	SHAFT		1
196	010102-000	RETAINING RING	RTW-32	1
197	190008-901	COLLAR		1
198	940119-000	MANUAL		1
199	945608-000	LABELS	MODEL T-20 (1PH 240V)	1
199	944867-000	LABELS	MODEL T-20 (3PH 415V)	1
199	945567-000	LABELS	MODEL T-20S	1
200	000103-102	CAP SCREW	M6*1.0P*10	2
205	048201-204	HEX LOCKING SCREW	M8*1.25P*30	1
208	021336-000	STRAINING RELIEF	MG25A-16B	1
210	008304-200	LOCKING NUT	M6*1.0P(10B*7H)	2
211	000303-105	SCREW	M5*0.8P*15	2
	850220-000	HARDWARE BAG		1
20	230114-906	HANDLE		1
176	040003-000	HEX SCREW	3mm	1
177	040004-000	HEX SCREW	4mm	1
178	040005-000	HEX SCREW	5mm	1
179	040006-000	HEX SCREW	6mm	1
180	040201-000	OPEN WRENCH	8*10	1
181	040204-000	OPEN WRENCH	12*14	1
182	040206-000	OPEN WRENCH	17*19	1
184	041203-006	PLASTIC BAG	610*110*0.15t	1
	850114-000	DUST HOOD HARDWARE BAG		1
13	000002-201	HEX SCREW	M6*1.0P*12	6
14	006002-032	FLAT WASHER	6.6*13*1.0t	6
183	041103-001	PLASTIC BAG	120*100*0.1t	1

WARNING

General Machinery Safety Instructions

Machinery House
requires you to read this entire Manual before using this machine.

- 1. Read the entire Manual before starting machinery.** Machinery may cause serious injury if not correctly used.
- 2. Always use correct hearing protection when operating machinery.** Machinery noise may cause permanent hearing damage.
- 3. Machinery must never be used when tired, or under the influence of drugs or alcohol.** When running machinery you must be alert at all times.
- 4. Wear correct Clothing.** At all times remove all loose clothing, necklaces, rings, jewelry, etc. Long hair must be contained in a hair net. Non-slip protective footwear must be worn.
- 5. Always wear correct respirators around fumes or dust when operating machinery.** Machinery fumes & dust can cause serious respiratory illness. Dust extractors must be used where applicable.
- 6. Always wear correct safety glasses.** When machining you must use the correct eye protection to prevent injuring your eyes.
- 7. Keep work clean and make sure you have good lighting.** Cluttered and dark shadows may cause accidents.
- 8. Personnel must be properly trained or well supervised when operating machinery.** Make sure you have clear and safe understanding of the machine you are operating.
- 9. Keep children and visitors away.** Make sure children and visitors are at a safe distance for you work area.
- 10. Keep your workshop childproof.** Use padlocks, Turn off master power switches and remove start switch keys.
- 11. Never leave machine unattended.** Turn power off and wait till machine has come to a complete stop before leaving the machine unattended.
- 12. Make a safe working environment.** Do not use machine in a damp, wet area, or where flammable or noxious fumes may exist.
- 13. Disconnect main power before service machine.** Make sure power switch is in the off position before re-connecting.
- 14. Use correct amperage extension cords.** Undersized extension cords overheat and lose power. Replace extension cords if they become damaged.
- 15. Keep machine well maintained.** Keep blades sharp and clean for best and safest performance. Follow instructions when lubricating and changing accessories.
- 16. Keep machine well guarded.** Make sure guards on machine are in place and are all working correctly.
- 17. Do not overreach.** Keep proper footing and balance at all times.
- 18. Secure workpiece.** Use clamps or a vice to hold the workpiece where practical. Keeping the workpiece secure will free up your hand to operate the machine and will protect hand from injury.
- 19. Check machine over before operating.** Check machine for damaged parts, loose bolts, Keys and wrenches left on machine and any other conditions that may effect the machines operation. Repair and replace damaged parts.
- 20. Use recommended accessories.** Refer to instruction manual or ask correct service officer when using accessories. The use of improper accessories may cause the risk of injury.
- 21. Do not force machinery.** Work at the speed and capacity at which the machine or accessory was designed.
- 22. Use correct lifting practice.** Always use the correct lifting methods when using machinery. Incorrect lifting methods can cause serious injury.
- 23. Lock mobile bases.** Make sure any mobile bases are locked before using machine.
- 24. Allergic reactions.** Certain metal shavings and cutting fluids may cause an allergic reaction in people and animals, especially when cutting as the fumes can be inhaled. Make sure you know what type of metal and cutting fluid you will be exposed to and how to avoid contamination.
- 25. Call for help.** If at any time you experience difficulties, stop the machine and call you nearest branch service department for help.

WARNING

Planer Thicknesser Safety Instructions

Machinery House

requires you to read this entire Manual before using this machine.

- 1. Maintenance.** Make sure the Planer Thicknesser is turned off and disconnect from the main power supply and make sure all moving parts have come to a complete stop before any inspection, adjustment or maintenance is carried out.
- 2. Planer Thicknesser Condition.** Planer Thicknesser must be maintained for a proper working condition. Never operate a Planer Thicknesser that has damaged or worn parts. Scheduled routine maintenance should be performed on a scheduled basis.
- 3. Blade/Cutter Condition.** Never operate a Planer Thicknesser with dropped, cracked or badly worn blades or cutters. Before using a Planer Thicknesser inspect all blades and cutters. A damaged blade or cutter can cause serious injury.
- 4. Hand Hazard.** Keep hands and fingers clear from the cutter-head, infeed & outfeed table supports. Serious injury can occur.
- 5. Leaving a Planer Thicknesser Unattended.** Always turn the Planer Thicknesser off and make sure all moving parts have come to a complete stop before leaving the Planer Thicknesser. Do not leave Planer Thicknesser running unattended for any reason.
- 6. Avoiding Entanglement.** Blade guard must be used at all times. Remove loose clothing, belts, or jewelry items. Never wear gloves while machine is in operation. Tie up long hair and use the correct hair nets to avoid any entanglement with the Planer Thicknesser moving parts.
- 7. Understand the machines controls.** Make sure you understand the use and operation of all controls.
- 8. Power outage.** In the event of a power failure during use of the Planer Thicknesser, turn off all switches to avoid possible sudden start up once power is restored.
- 9. Work area hazards.** Keep the area around the Planer Thicknesser clean from oil, tools, chips. Pay attention to other persons in the area and know what is going on around the area to ensure unintended accidents.
- 10. Workpiece Handling.** Supporting the work-piece adequately with additional supports at all times while cutting. This is crucial for making safe cuts and avoiding injury. Never attempt to make a cut with an unstable work-piece. Ensure work piece has stopped feeding before handling.
- 11. Hearing protection and hazards.** Always wear hearing protection as noise generated from cutter-head and work-piece vibration can cause permanent hearing loss over time.
- 12. Thicknesser Infeed clearance safety.** The infeed roller is designed to pull the work-piece into the cutter-head. Always keep hands, clothing, hair away from the infeed roller during operation to prevent serious injury.
- 13. Never look inside thicknesser.** Wood chips fly around inside the thicknesser at a high rate of speed. Do not look inside the thicknesser remove guards or covers during operation.
- 14. Operating position.** The work-piece may kick out during operation. To avoid getting hit, stand to the side of the machine during the entire operation.
- 15. Use correct material.** Only use natural timber. Do not use MDF, plywood, laminates, or other synthetic or man-made products. Thicknessing material not designed for this machine may cause serious injury.
- 16. Planer Cutter-head Alignment.** The top edge of the outfeed table should be aligned with the edge of the knife at top dead centre to avoid kickback. An unaligned table can cause serious injury.
- 17. Joining with the grain.** Jointing against the grain or jointing end grain is dangerous and could produce chatter or excessive chip out. Always joint with the grain.
- 18. Thicknessing Grain direction.** Thicknessing across the grain may cause the work-piece to kick out. Always thickness with the wood grain or at a small angle.
- 19. Use a Push Stick.** Always use a push stick when whenever surface planing. Never pass your hands directly over the cutter-head without a push stick.
- 20. Blade guards.** Always use blade guards except when rebating. Make sure you replace the guard after rebating.
- 21. Planer Cutting operation.** Always keep the work-piece moving toward the outfeed table until the work-piece has passed completely over the cutter-head. Never feed the work-piece toward the infeed table.
- 22. Stalled blade.** In the case that the cutter-head stalls while in operation, turn the Planer Thicknesser off before freeing the stalled cutter-head.
- 23. Changing between Planer / Thicknesser mode.** Once changed to the required mode either Planer or Thicknesser, always ensure all safety guards and dust chutes are re-fitted before starting machine.
- 24. Work-piece safety.** Inspect your work-piece carefully before feeding it over the cutter-head. Never thickness material that has knots, nails, or staples.
- 25. Dust hazards.** Always use a dust collector when using machine.
- 26. Kickback.** Kickback is defined as high speed expulsion of work-piece from the Planer Thicknesser table cutter-head. Never stand in the kickback zone.
- 27. Call for help.** If at any time you experience difficulties, stop the machine and call your nearest branch service department for help.

PLANT SAFETY PROGRAM

NEW MACHINERY HAZARD IDENTIFICATION, ASSESSMENT & CONTROL

Planer Thicknesser

Developed in Co-operation Between A.W.I.S.A and Australia Chamber of Manufactures
This program is based upon the Safe Work Australia, Code of Practice - Managing Risks of Plant in the Workplace (WHSA 2011 No10)

Item No.	Hazard Identification	Hazard Assessment	Risk Control Strategies <small>(Recommended for Purchase / Buyer / User)</small>
A	ENTANGLEMENT CRUSHING	HIGH MEDIUM	Eliminate, avoid loose clothing / Long hair etc. Heavier timber must be supported Be sure that when rising and falling planner tables hands are well away from locating, clamping and pivoting area.
B			Keep hands clear from infeed & outfeed support rollers during operation.
C	CUTTING, STABBING, PUNCTURING	MEDIUM	Isolate power to machine prior to any checks or maintenance. Do not open or clean inside until the machine has completely stopped. Keep hands clear of all blades and moving parts. Use a push stick where necessary. Care must be taken when handling knives.
D	SHEARING	MEDIUM	Make sure all guards are secured shut when machine is on.
F	STRIKING	MEDIUM	Do not stand behind timber when feeding into machine. A face mask must be worn at all times. Ensure to use correct feed rates for material.
H	ELECTRICAL	MEDIUM	All electrical enclosures should only be opened with a tool that is not to be kept with the machine. Machine should be installed & checked by a Licensed Electrician.
O	OTHER HAZARDS, NOISE, DUST.	LOW	Wear hearing protection as required. Must be connected to dust extraction
Plant Safety Program to be read in conjunction with manufactures instructions			



www.machineryhouse.com.au



www.machineryhouse.co.nz

Authorised and signed by:

Safety officer:

Manager:

Revised Date: 29th June 2018